



# AVK INDUSTRIAL PRODUCTS



## *Engineering Manual*

### **MARKET LEADERS IN BLIND THREADED INSERTS AND STUDS**

AVK's Quality Management System is registered to ISO/TS16949:2002 and ISO9001:2000

AVK's Environmental Management System is registered to ISO14001:1996

# WELCOME TO THE WORLD OF AVK

**AVK INDUSTRIAL PRODUCTS**, located in Valencia, CA, is a member of SPS Fastener Division Group, a Precision Castparts Company. AVK manufactures blind installed threaded fasteners for transportation and general industrial markets worldwide. We feature product lines of both unified (INCH) and metric fasteners along with numerous special designs that meet customer application requirements.



**At AVK, we are dedicated to...**

**“IMPROVING THE WAY WE ASSEMBLE THE WORLD™”**

## BLIND INSTALLED THREADED INSERTS AND STUDS

A blind installed threaded fastener is defined as a fastener with internal or external threads that can be installed into a panel, tube or other structure from the front side without need to see or access the backside, or “blind” side to complete the installation. Once installed the fastener remains captive to which a mating component can be attached using standard hardware.

This engineering manual contains technical information on all AVK standardized product lines including sales drawings and information on installation tooling.



## WARRANTY

### LIMITED WARRANTY AND EXCLUSIVE REMEDY

AVK Industrial Products division of Avibank Mfg., Inc. – which is a subsidiary of Precision Castparts (“Seller”). Seller warrants that products sold hereunder conform to industry standards specified herein and will be free from defects in materials and workmanship. THIS WARRANTY IS EXPRESSLY GIVEN IN LIEU OF ANY AND ALL OTHER EXPRESS OR IMPLIED WARRANTIES, INCLUDING ANY IMPLIED WARRANTY OF MERCHANTABILITY OR FITNESS FOR A PARTICULAR PURPOSE, AND IN LIEU OF ANY OTHER OBLIGATION ON THE PART OR THE SELLER. Seller will, at its option, repair or replace free of charge (excluding all shipping and handling costs) any products which have not been subject to misuse, abuse or modification and which in its sole determination were not manufactured in compliance with the warranty given above.

It is expressly understood that any technical advice furnished by or on behalf of Seller with respect to the use of its goods or services is given without charge, and Seller assumes no obligations or liability for the advice given or results obtained. All such results being given and accepted is at Buyer's Risk.





























THE REMEDY PROVIDED FOR HEREIN SHALL BE THE EXCLUSIVE REMEDY FOR ANY BREACH OF WARRANTY OR ANY CLAIM ARISING IN ANY WAY OUT OF THE MANUFACTURE, SALE, OR USE OF THESE PRODUCTS. In no event shall Seller be liable for consequential, incidental or any other damages of any nature whatsoever except those specifically provided herein for any breach of warranty or any claim arising in any way out of the manufacture, sale, or use of these products. No other person is authorized by Seller to give any other warranty, written or oral, pertaining to the products.



# ENGINEERING MANUAL

This engineering manual contains the full AVK product line, application ideas, features and benefits, sales drawings with dimensions and tolerances, material and finish specifications, and technical information on the selection and use of all installation tooling.

## PRODUCT INDEX

ITEM	PAGE
Welcome to the World of AVK .....	2
AVK Product Index .....	3
Capabilities .....	4
Product Introduction .....	5
Spinwall Technology .....	6
Advantages .....	7
Typical AVK Applications .....	8-9
  A-L Series™ Knurled Threaded Insert.....	10-11
  A-K Series™ Knurled Threaded Insert.....	12-13
  A-H Series™ Threaded Hex Insert.....	14-15
  A-R Series™ Threaded Insert .....	16-17
  A-L Series™ Sealed Head Threaded Insert .....	18
  A-H Series™ Sealed Head Threaded Hex Insert.....	19
  A-S Series™ Captive Threaded Stud.....	20-21
  A-T Series™ Knurled Threaded Insert.....	22-23
  A-W Series® Knurled Threaded Insert.....	24
  A-O Series™ Threaded Insert .....	25
  R-N Series® Rivet Nut Threaded Insert .....	26-27
  ARO Spin-Spin Pneumatic Tools .....	28-33
  SPP2™ Spin Pull to Pressure Tools.....	34-35
  Dyna-Set™ Automation Tools.....	36
<b>TOOLS</b> Miscellaneous Pneumatic/Hydraulic Tools .....	37
<b>HAND TOOLS/KITS</b> Hand Tools and Kits .....	38-40
<b>DESIGN CONSIDERATIONS</b> Guidelines for Successful Applications.....	41
<b>TEST DATA</b> Basic Test Data .....	42
<b>TECH DATA</b> Dimensional Conversions .....	43

# CAPABILITIES



## AVK SALES PROFESSIONALS:

AVK's sales representatives and customer service staff are dedicated to assist our customers in providing demonstrations, samples, and technical support. Our global network of Authorized Distributors assist in these efforts and provide for our customer's logistical product needs.

## ENGINEERING SUPPORT:

AVK's engineering and installation tool support staff transforms our customers needs and ideas into robust designs that have become industry standards for innovation and reliability.



## MANUFACTURING:

Housed in a 80,000 sq. ft. facility, AVK utilizes state of the art cold forming equipment to produce net shape products at speeds of up to 240 pieces per minute. Secondary customized internal thread rolling, assembly equipment and a "Lean" manufacturing philosophy help to produce product that exceeds our customers expectations from quality and delivery.

## QUALITY:

Our staff of quality experts are dedicated to the principles of ISO/TS16949 and ISO14001. They are continuously working to improve an already world class quality product to even higher levels.





# PRODUCT INTRODUCTION

AVK has developed specific manufacturing technology that sets our products apart from other blind installed fastener manufacturers. We call what we do "Spinwall Technology." AVK's Spinwall Technology™ blind installed fasteners consist of two types. Internally threaded inserts and externally threaded studs. Both products can be installed into a flat, tubular or other shaped materials using hand operated or pneumatic hand held tools right on your assembly line without adjustment even if the parent material varies in thickness. Our products can be installed after paint or other finishes is applied to your product which eliminates the need for thread masking.

# INSTALLATION SEQUENCE

**Here is how the AVK product is installed "blind."**

<p>1/4 turn the AVK fastener onto the tool's threaded mandrel.</p>	<p>The fastener is placed into the hole.</p>	<p>The forward trigger is depressed and the fastener is installed properly.</p>	<p>The reverse trigger is depressed and the tool unthreads from the installed fastener.</p>	<p>The mating component is then attached using conventional hardware.</p>

# SPINWALL TECHNOLOGY™ PRODUCT DESIGN

<p><b>AL SERIES</b> Round serrated body threaded insert for excellent spin out resistance in drilled or punched holes. Available in steel, aluminum, brass, and monel.</p>	<p><b>AH SERIES</b> Hex Body threaded insert for punched holes provides exceptional spin out resistance. Available in steel, brass and 302 stainless steel.</p>	<p><b>AR SERIES</b> Pre-Bulbed slotted body design for exceptional pull out resistance in drilled or punched holes in plastics, composites and thin sheet metal applications. Available in steel.</p>	<p><b>AS SERIES</b> Round serrated body threaded stud is ideal as a location device to support heavy components before final installation with a mating nut. Available in steel.</p>

# INSTALLATION TOOL TYPES

<p>The expendable tool is used for lower consumer cost or field installations.</p>	<p>The lever or plier style tools are used for experimental or field installations.</p>	<p>The pneumatic tool is used for production line work.</p>	<p>The Dyna-Set™ automation system is used for automated installations.</p>

# SPINWALL TECHNOLOGY™

## Spinwall Technology™...Sets AVK apart

You will notice throughout this catalog references to the phrase Spinwall Technology™. This phrase describes the philosophy of our product's design, manufacturing and installation systems.

Our Spinwall Technology™ products are manufactured on high-speed, state-of-the-art cold forming equipment on which very precise tolerances are achieved. This capability allows AVK to produce products with unique mechanical and installation properties that result in the AVK product filling the hole prior to backside flange formation. Read more about hole fill and the other advantages of Spinwall Technology™ on the separate product profile pages.

**Our Spinwall Technology™ products can be installed using three different types of installation tooling...**

## ARO PNEUMATIC STALL TORQUE TOOL

The ARO pneumatic stall torque type tool installs AVK as follows...

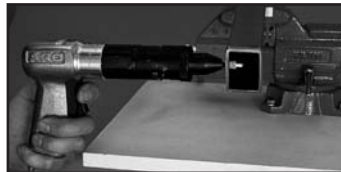

1/4 turn the fastener onto the ARO tool mandrel and place the fastener into the hole.



Depress the top trigger until the tool stalls and the AVK fastener is collapsed.



Depress the lower trigger and the tool unthreads from the installed part.

## AVK SPP™ SPIN PULL TO PRESSURE TOOL

The SPP tool utilizes an ARO pneumatic stall torque tool and incorporates an integrated hydraulic cylinder powered by a remote hydraulic power pack system.



1/4 turn the fastener onto the SPP tool mandrel and place the fastener into the hole.



Depress the tool trigger and the tool spins into the fastener and automatically exerts a pressure controlled pull installing the fastener.



Depress the tool reverse trigger and the tool spins out of the installed fastener.



## Dyna-Set™ Technology

The patent-pending design of the Dyna-Set™ automated insert system and Material Handling Module utilizes spin pull technology. The Dyna-Set™ will replace antiquated canister pneumatic hydraulic spin pull to stroke tools and provide greater reliability and maximize assembly capability.

Some of the Dyna-Set™ benefits are as follows:

- ◆ Labor savings
- ◆ Single or multi-simultaneous insert installation
- ◆ Maximum up-time providing optimal production output
- ◆ Multiple work station configurations are available
- ◆ Robotic arm with hole locating vision system is available
- ◆ Insert collapse load can be verified
- ◆ Dyna-Set™ systems are self diagnostic



# ADVANTAGES OF ASSEMBLY WITH AVK

Here are a few reasons why the use of AVK's blind installed fasteners are "Improving The Way We Assemble The World"™

Material thickness is being reduced to save weight, fuel-pollution and raw material cost. Fastening to thin materials is simple and reliable with AVK. AVK fasteners can be installed into thinner materials with greater ease than can be accomplished with weld nuts, pierce nuts, clinch nuts, thread tapping and thread forming screws.

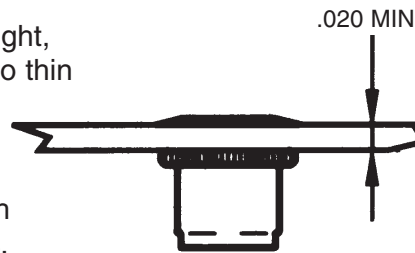

\*Minimum grips vary per thread size

**INSTALLS BLIND**

New material structures such as hydro formed tubing, aluminum extrusions and composite panels are being specified due to their strength to weight ratios. These materials form blind applications are ideal for AVK fasteners versus other types of fasteners.

Welding and the attachment of weld fasteners are being replaced with AVK due to health and clean air requirements for workers. The alternatives are expensive capital equipment vacuuming and air scrubber equipment. Weld fasteners also burn away pre-applied galvanized finishes requiring re-work to prevent corrosion. Pre-painted materials cannot be used with weld fasteners as the paint prevents weld nut attachment. Use of pre-painted materials can eliminate painting facility costs and environmental issues. Weld fasteners must be applied before a product is painted. Thread masking procedures are eliminated by the use of AVK as our products can be installed after paint.



Plastics and composites are being used for products to take advantage of their molding, corrosion resistance, coloring and strength to weight ratios. AVK has specific products for blow, rotational, compression, vacuum, scrim, honeycomb, processed plastic and composites.

Products designed for consumer assembly to reduce in plant assembly costs use AVK to provide strong threads for the attachment of component parts using conventional hardware.

# TYPICAL AVK APPLICATIONS

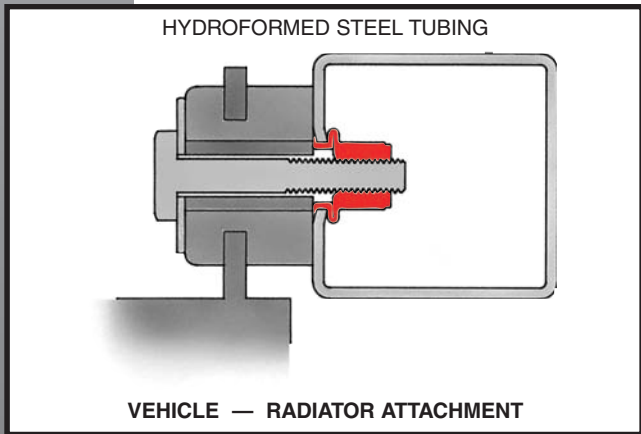
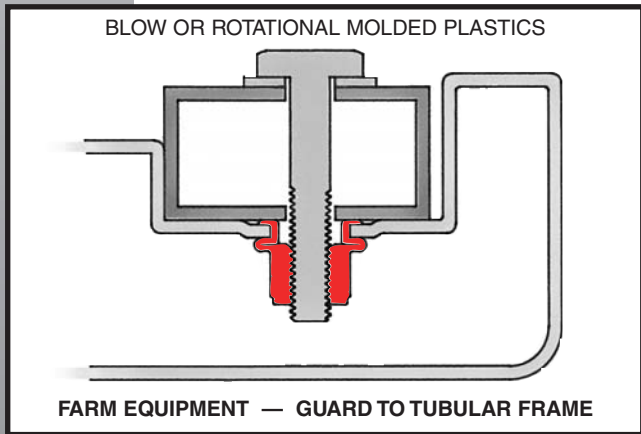
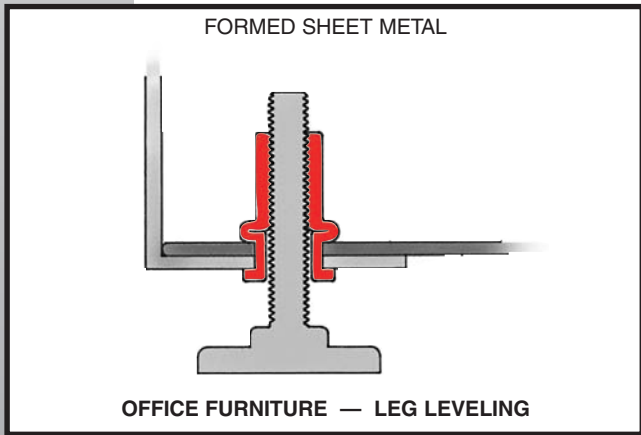
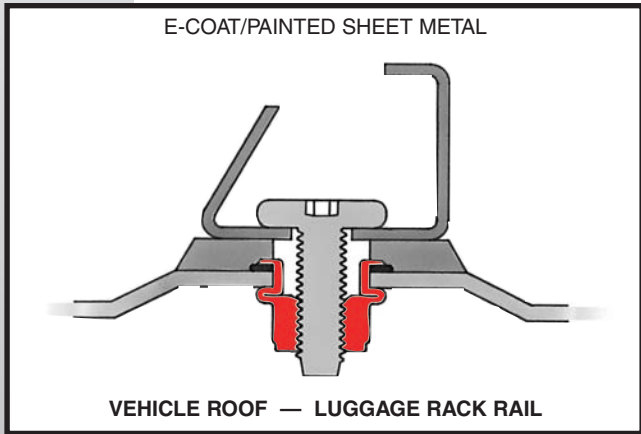

- ◆ **LAWN/GARDEN FARM IMPLEMENT**  
Mirrors/Lights to Cab • Components to Decking • Guards to Framing • Seats to Framing • Access Panels to Frame
- ◆ **MEDICAL EQUIPMENT**  
Wheelchair Hand Rims • Wheelchair Seats/Backs • Handles/Casters to Carts • Components to Hospital Beds • Aluminum Walker Assembly
- ◆ **MILITARY GROUND SUPPORT**  
Ducts/Wireways to Shelters • Electronics to Shelters • Missile Container Assembly • Antenna Assembly • Hardware to Shelters
- ◆ **MILITARY VEHICLES**  
Side Mirrors to Body • Armor to Body • Bulletproof Glass to Body • Instruments to Dash • Cargo Hold Down to Floor Pan
- ◆ **OFFICE FURNITURE**  
Modular Unit Stacking • Hardware/Hinges to Unit • Leg Leveling • Knock-Down Assembly • Partition Electrical Components
- ◆ **RECREATION**  
Playground Equipment Assembly • Bicycle Frame Water Bottle Attachment • Basketball Pole Assembly • Golf Cart Roof Supports to Body • Consumer Assembly of Toys
- ◆ **REFRIGERATION**  
Hinges to Doors/Cabinet • Handles to Doors • Shelf Brackets to Wall • Compressor to Base Pan • Leg Leveling
- ◆ **RV INDUSTRY**  
Instruments to Boat Dash • Bow Rails to Deck • Components to Snowmobile • Components to Motorcycles • RV Awning Assembly
- ◆ **TRUCKS/TRAILERS**  
Mirrors/Lights to Cab • Grab Handles to Cab • Firewall Attachments • Instruments to Dash • Exhaust/Wind Deflectors

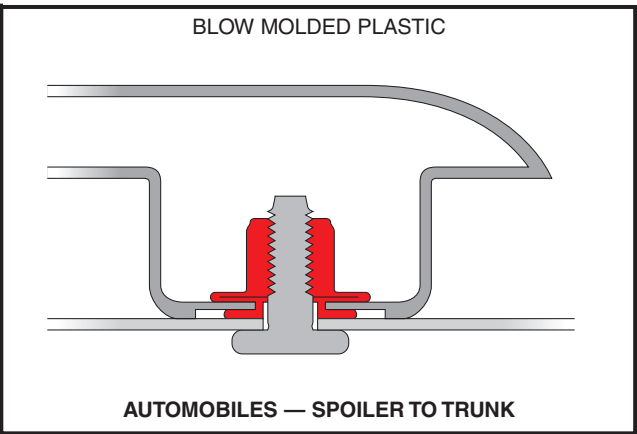

# TYPICAL AVK APPLICATIONS

◆ **AEROSPACE**

Galley Equipment Casters to Frame • Aircraft Seating Footrests to Frame • Aircraft Seat Trays to Frame • Bulkhead Partition Mounting Brackets • Shipping Container Hinges and Latches to Frame

◆ **APPLIANCES**

Refrigerator Hinge to Cabinet • Refrigerator Handle to Door • Leg Leveler • Components to Cabinet • Under the Counter Attachments

◆ **ARCHITECTURAL**

Vinyl Window Hardware to Frame • Aluminum Door Hardware to Frame • Threshold Sweeps to Frame • Aluminum Railing "T" Joints • Patio Enclosure Construction

◆ **AUTO/SPORT-UTILITY VEHICLES**

Luggage Racks to Roof • Spoilers to Trunk Lids • Option Controls to Dash Panel • Under Hood Option Items • Grab Handles • Air Bag Attachments

◆ **ELECTRONICS CABINETRY**

Hardware to Cabinet • Hinges to Cabinet • Leg Levelers • Components to Frame • Lifting Anchors

◆ **EXERCISE EQUIPMENT**

Stationary Bike Floor Supports to Frame • Treadmill Controls to Frame • Sheet Metal Covers over Motors • Weightlifting Frame Assembly • Electronics to Unit

◆ **FOOD SERVICE**

Leg Leveling • Fixed Leg Attachment • Coin Box to Unit • Hardware to Cabinet • Casters to Frame

◆ **FURNITURE**

Aluminum Furniture Assembly • Leg Leveling • Brass Headboards to Frame • Patio Table Assembly • Tubular Bed Frame Assembly

◆ **HEATING/AIR CONDITIONING**

Compressors to Base Pans • Access Doors to Cabinet • Motors to Blower Housing • Blower Housing to Unit • Burner Assembly to Unit

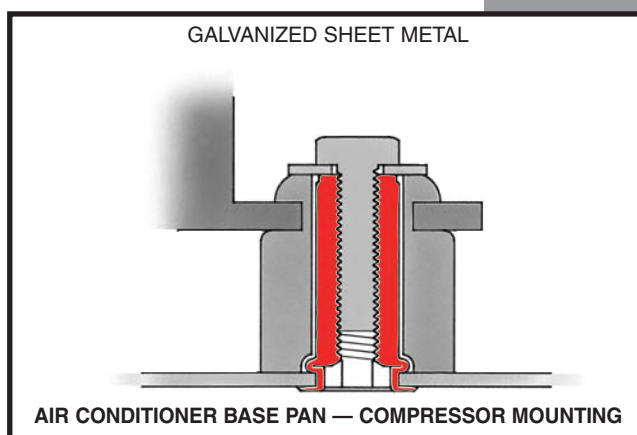
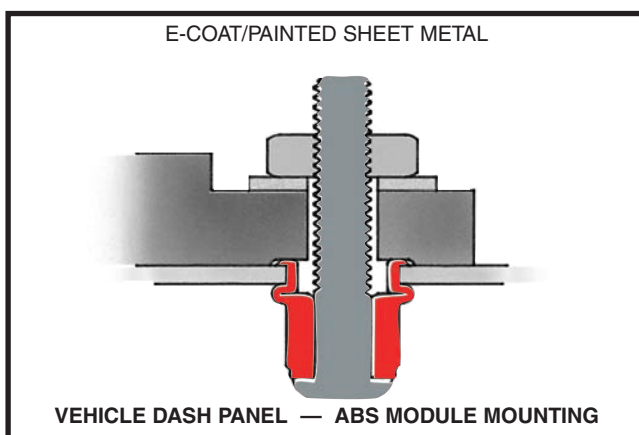
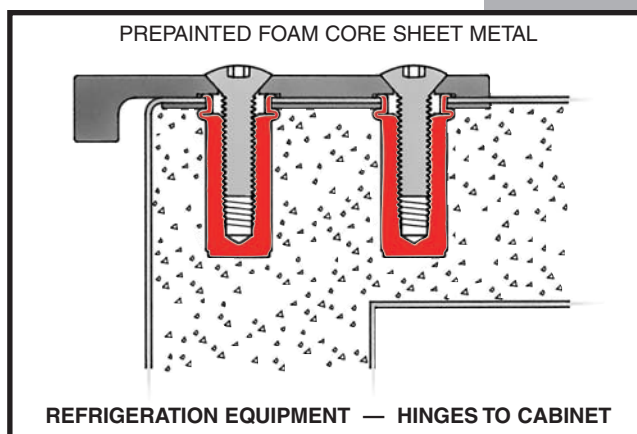
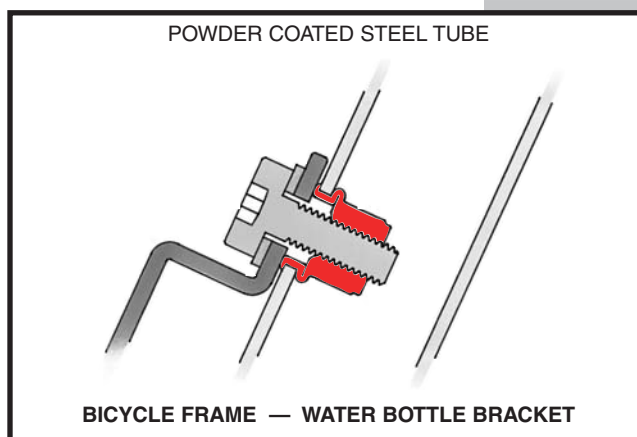
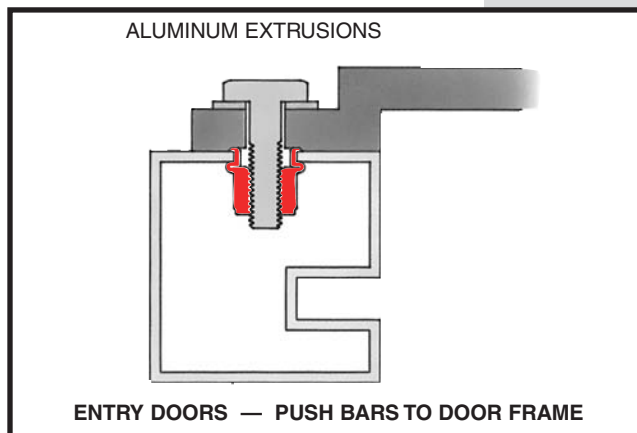

## A-L SERIES INSERT PROFILE

The **A-L Series Insert** features a knurled body and large diameter—low profile head making it ideal for use in punched or drilled holes. It offers the highest all around strength characteristics and has been designed to be used with Grade 5 or Metric 8.8/9.8 mating screws. The A-L Series is AVK's most versatile performer.

The A-L Series Insert can be installed using AVK's ARO brand pneumatic tools or AVK's SPP™ pneumatic/hydraulic tooling. These tools can be located at any position on your assembly line. The A-L Series can be installed either before or after finish.

### SPINWALL TECHNOLOGY™

#### HOW HOLE FILL WORKS FOR YOU

As the A-L Series is installed, the knurled body expands 360°

#### FILLING THE HOLE.

This feature provides exceptional torque strength and vibration resistance.

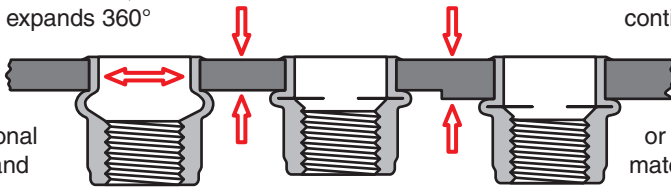

The installation tool then continues to install the insert forming a backside flange even in multiple or variable thickness materials—**WITHOUT ADJUSTMENT.**

## DESIGN BENEFITS

- ◆ **EXCEPTIONAL TORQUE STRENGTH** is achieved as the insert's knurled body expands **FILLING THE HOLE.**
- ◆ **QUALITY INSTALLATIONS** even in variable thickness materials are assured by AVK's spin/spin ARO pneumatic tools and our SPP pneumatic hydraulic tools.
- ◆ **SUPERIOR THREAD STRENGTH** is provided due to our internal rolled thread manufacturing process.
- ◆ **THREADS GAUGE** before and after installation due to the increased cross-sectional thickness of the thread area. Thread dilation is prevented.
- ◆ **INVENTORY REDUCTION** is possible because of the A-L Series' wide grip range capacity. It is 2.5 times greater than conventional rivet nuts.
- ◆ **SUPERIOR CORROSION RESISTANCE** is provided by our standard zinc/yellow dichromate finish (96 hours. salt spray to white corrosion). For exceptional corrosion protection we offer a tin/zinc alloy finish.
- ◆ **AVAILABLE** in steel. Additional materials such as aluminum, brass and monel are available by special order. Contact AVK for details.

## ADDITIONAL DESIGN TYPES

#### CLOSED END

Thread area is enclosed eliminating leakage past the threads from either side of the application. See page 11.



#### SEALED HEAD

A PVC foam seal is bonded to the underside of the head and when installed provides a weathertight seal. (Also available in the closed end version.) See page 18 for important grip information.



#### WEDGE HEAD

The addition of wedges under the head provides even greater torque capability, especially in soft or thin materials, and is excellent for electrical grounding applications. Contact AVK for a sales drawing.



# UNIFIED (INCH) AND METRIC THREAD SIZES

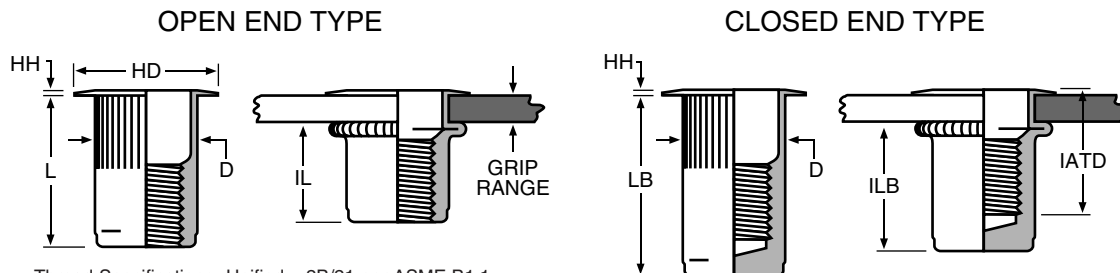

Thread Specifications: Unified 2B/21 per ASME B1.1  
Metric 6H/21 per ASME B1.13M

THREAD SIZE	THREAD CALL OUT	GRIP RANGE	GRIP CALL OUT	HOLE SIZE +.006 -.000	HD ±.010 ±.025*	HH ±.003	L ±.015	D MAX.	IL MAX.	LB ±.015	ILB MAX.	IATD* MAX.
6-32 UNC	632	.020-.080	80	17/64 (.2656)	.390	.030	.420	.265	.305	.740	.640	.610
6-32 UNF	632	.080-.130	130	17/64 (.2656)	.390	.030	.470	.265	.305	.740	.580	.670
8-32 UNC	832	.020-.080	80	17/64 (.2656)	.390	.030	.420	.265	.305	.740	.640	.610
8-32 UNF	832	.080-.130	130	17/64 (.2656)	.390	.030	.470	.265	.305	.740	.580	.670
10-24 UNC	1024	.020-.130	130	19/64 (.2969)	.415	.030	.475	.296	.315	.990	.845	.730
10-24 UNF	1024	.130-.225	225	19/64 (.2969)	.415	.030	.585	.296	.315	.990	.735	.840
10-32 UNF	1032	.020-.130	130	19/64 (.2969)	.415	.030	.475	.296	.315	.990	.845	.730
10-32 UNC	1032	.130-.225	225	19/64 (.2969)	.415	.030	.585	.296	.315	.990	.735	.840
1/4-20 UNC	420	.027-.165	165	25/64 (.3906)	.500	.030	.580	.390	.380	1.190	1.005	.895
1/4-20 UNF	420	.165-.260	260	25/64 (.3906)	.500	.030	.680	.390	.380	1.190	.905	1.035
5/16-18 UNC	518	.027-.150	150	17/32 (.5312)	.685*	.035	.690	.530	.470	1.390	1.175	.995
5/16-18 UNF	518	.150-.312	312	17/32 (.5312)	.685*	.035	.805	.530	.425	1.390	1.025	1.120
3/8-16 UNC	616	.027-.150	150	17/32 (.5312)	.685*	.035	.690	.530	.470	1.390	1.175	.995
3/8-16 UNF	616	.150-.312	312	17/32 (.5312)	.685*	.035	.805	.530	.425	1.390	1.025	1.120
1/2-13 UNC	813	.063-.200	200	11/16 (.6875)	.865*	.047	1.150	.685	.850	2.365	2.070	1.505
1/2-13 UNF	813	.200-.350	350	11/16 (.6875)	.865*	.047	1.300	.685	.850	2.365	1.920	1.505
1/2-13 UNC	813	.350-.500	500	11/16 (.6875)	.865*	.047	1.450	.685	.860	2.365	1.770	1.505

THREAD SIZE	THREAD CALL OUT	GRIP RANGE	GRIP CALL OUT	HOLE SIZE +0.15 -0.00	HD ±0.25 ±0.64*	HH ±0.08	L ±0.38	D MAX.	IL MAX.	LB ±0.38	ILB MAX.	IATD* MAX.
M4 x 0,7 ISO	470	0,50-2,00	2.0	6,75	9,91	0,76	10,67	6,73	7,75	18,80	16,26	15,49
M4 x 0,7 ISO	470	2,00-3,30	3.3	6,75	9,91	0,76	11,94	6,73	7,75	18,80	14,73	17,02
M5 x 0,8 ISO	580	0,50-3,30	3.3	7,60	10,54	0,76	12,07	7,52	8,00	25,15	21,46	18,54
M5 x 0,8 ISO	580	3,30-5,70	5.7	7,60	10,54	0,76	14,86	7,52	8,00	25,15	18,67	21,34
M6 x 1,0 ISO	610	0,70-4,20	4.2	10,00	12,70	0,76	14,73	9,91	9,65	30,23	25,53	22,73
M6 x 1,0 ISO	610	4,20-6,60	6.6	10,00	12,70	0,76	17,27	9,91	9,65	30,23	22,99	26,29
M8 x 1,25 ISO	8125	0,70-3,80	3.8	13,50	17,40*	0,89	17,53	13,46	11,94	35,31	29,85	25,27
M8 x 1,25 ISO	8125	3,80-7,90	7.9	13,50	17,40*	0,89	20,45	13,46	10,80	35,31	26,04	28,45
M10 x 1,5 ISO	1015	0,70-3,80	3.8	13,50	17,40*	0,89	17,53	13,46	11,94	35,31	29,85	25,27
M10 x 1,5 ISO	1015	3,80-7,90	7.9	13,50	17,40*	0,89	20,45	13,46	10,80	35,31	26,04	28,45
M12 x 1,75 ISO	12175	1,60-5,10	5.1	17,45	21,97*	1,19	29,21	17,4	21,59	60,07	52,58	38,23
M12 x 1,75 ISO	12175	5,10-8,90	8.9	17,45	21,97*	1,19	33,02	17,4	21,59	60,07	48,77	38,23
M12 x 1,75 ISO	12175	8,90-12,7	12.7	17,45	21,97*	1,19	36,83	17,4	21,84	60,07	44,96	38,23

**NOTE 1:** Grip range can be affected by parent material density and actual hole size. AVK suggests trial installations to determine optimum grip. **NOTE 2:** Additional UNF fine threads are available. Contact AVK for details. **NOTE 3:** Additional grip lengths are available. Contact AVK for details. \*Dimensions in minimum grip condition.

# PART NUMBERING SYSTEM

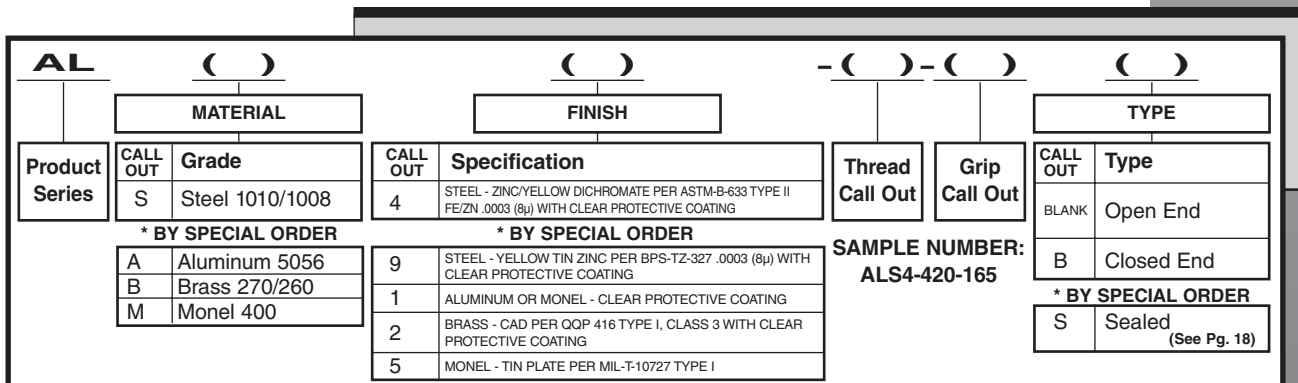

\* Special order items are subject to minimum order requirements. Contact AVK for details.

For air tool selection see pages 28 and 30

## A-K SERIES INSERT PROFILE

The **A-K Series Insert** features a knurled body and a reduced profile head to allow for virtually flush installation. Countersink drilling or dimpling of the parent material can be eliminated. The A-K Series is designed to be used with Grade 5 or Metric Class 8.8/9.8 mating screws.

The A-K Series Insert can be installed using AVK's ARO brand pneumatic tools or AVK's SPP<sup>TM</sup> pneumatic/hydraulic tooling. These tools can be located at any position on your assembly line. The A-K Series Insert can be installed either before or after finish.



## SPINWALL TECHNOLOGY<sup>TM</sup>

### HOW HOLE FILL WORKS FOR YOU

As the A-K Series is installed, the knurled body expands 360°

#### FILLING THE HOLE.

This feature provides exceptional torque strength and vibration resistance.

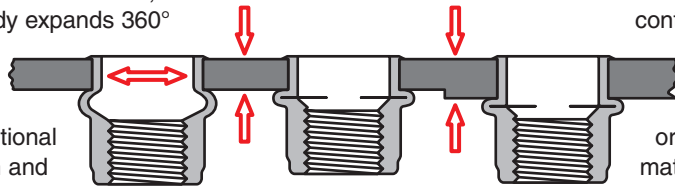

The installation tool then continues to install the insert forming a backside flange even in multiple or variable thickness materials—**WITHOUT ADJUSTMENT.**

## DESIGN BENEFITS

- ◆ **VIRTUALLY FLUSH INSTALLATIONS** are achieved without special hole preparation due to the A-K Series minimal head profile.
- ◆ **EXCEPTIONAL TORQUE STRENGTH** is achieved as the insert's knurled body expands **FILLING THE HOLE.**
- ◆ **QUALITY INSTALLATIONS** even in variable thickness materials are assured by AVK's spin/spin ARO pneumatic tools and our SPP<sup>TM</sup> pneumatic/hydraulic tools.
- ◆ **SUPERIOR THREAD STRENGTH** is provided due to our internal rolled thread manufacturing process.
- ◆ **THREADS GAUGE** before and after installation due to the increased cross-sectional thickness of the thread area. Thread dilation is prevented.
- ◆ **INVENTORY REDUCTION** is possible because of the A-K Series' wide grip range capacity. It is 2.5 times greater than conventional rivet nuts.
- ◆ **SUPERIOR CORROSION RESISTANCE** is provided by our standard zinc/yellow dichromate finish (96 hours. salt spray to white corrosion). For exceptional corrosion protection we offer a tin/zinc alloy finish.
- ◆ **AVAILABLE** in steel. Additional materials such as aluminum, brass and monel are available by special order. Contact AVK for details.

## ADDITIONAL DESIGN TYPES

### CLOSED END

Thread area is enclosed eliminating leakage past the threads from either side of the application.

See page 13.



# UNIFIED (INCH) AND METRIC THREAD SIZES

OPEN END TYPE

CLOSED END TYPE

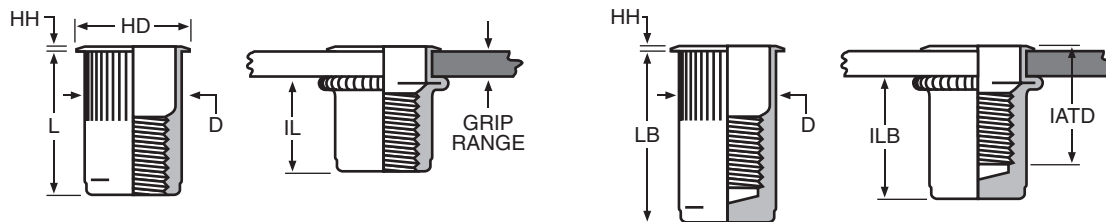

Thread Specifications: Unified 2B/21 per ASME B1.1  
Metric 6H/21 per ASME B1.13M

THREAD SIZE	THREAD CALL OUT	GRIP RANGE	GRIP CALL OUT	HOLE SIZE +.006 -.000	HD ±.010	HH ±.002	L ±.015	D MAX.	IL MAX.	LB ±.015	ILB MAX.	IATD* MAX.
6-32 UNC	632	.020-.080	80	17/64 (.2656)	.310	.019	.420	.265	.305	.740	.640	.610
6-32 UNC	632	.080-.130	130	17/64 (.2656)	.310	.019	.470	.265	.305	.740	.580	.670
8-32 UNC	832	.020-.080	80	17/64 (.2656)	.310	.019	.420	.265	.305	.740	.640	.610
8-32 UNC	832	.080-.130	130	17/64 (.2656)	.310	.019	.470	.265	.305	.740	.580	.670
10-24 UNC	1024	.020-.130	130	19/64 (.2969)	.340	.019	.475	.296	.315	.990	.845	.730
10-24 UNC	1024	.130-.225	225	19/64 (.2969)	.340	.019	.585	.296	.315	.990	.735	.840
10-32 UNF	1032	.020-.130	130	19/64 (.2969)	.340	.019	.475	.296	.315	.990	.845	.730
10-32 UNF	1032	.130-.225	225	19/64 (.2969)	.340	.019	.585	.296	.315	.990	.735	.840
1/4-20 UNC	420	.027-.165	165	25/64 (.3906)	.455	.022	.580	.390	.380	1.190	1.005	.895
1/4-20 UNC	420	.165-.260	260	25/64 (.3906)	.455	.022	.680	.390	.380	1.190	.905	1.035
5/16-18 UNC	518	.027-.150	150	17/32 (.5312)	.595	.022	.690	.530	.470	1.390	1.175	.995
5/16-18 UNC	518	.150-.312	312	17/32 (.5312)	.595	.022	.805	.530	.425	1.390	1.025	1.120
3/8-16 UNC	616	.027-.150	150	17/32 (.5312)	.595	.022	.690	.530	.470	1.390	1.175	.995
3/8-16 UNC	616	.150-.312	312	17/32 (.5312)	.595	.022	.805	.530	.425	1.390	1.025	1.120

THREAD SIZE	THREAD CALL OUT	GRIP RANGE	GRIP CALL OUT	HOLE SIZE +0,15 -0,00	HD ±0,25	HH ±0,05	L ±0,38	D MAX	IL MAX	LB ±0,38	ILB MAX	IATD* MAX
M4 x 0,7 ISO	470	0,50-2,00	2,0	6,75	7,87	0,48	10,67	6,73	7,75	18,80	16,26	15,49
M4 x 0,7 ISO	470	2,00-3,30	3,3	6,75	7,87	0,48	11,94	6,73	7,75	18,80	14,73	17,02
M5 x 0,8 ISO	580	0,50-3,30	3,3	7,60	8,64	0,48	12,07	7,52	8,00	25,15	21,46	18,54
M5 x 0,8 ISO	580	3,30-5,70	5,7	7,60	8,64	0,48	14,86	7,52	8,00	25,15	18,67	21,34
M6 x 1,0 ISO	610	0,70-4,20	4,2	10,00	11,56	0,55	14,73	9,91	9,65	30,23	25,53	22,73
M6 x 1,0 ISO	610	4,20-6,60	6,6	10,00	11,56	0,55	17,27	9,91	9,65	30,23	22,99	26,29
M8 x 1,25 ISO	8125	0,70-3,80	3,8	13,50	15,11	0,55	17,53	13,46	11,94	35,31	29,85	25,27
M8 x 1,25 ISO	8125	3,80-7,90	7,9	13,50	15,11	0,55	20,45	13,46	10,80	35,31	26,04	28,45
M10 x 1,5 ISO	1015	0,70-3,80	3,8	13,50	15,11	0,55	17,53	13,46	11,94	35,31	29,85	25,27
M10 x 1,5 ISO	1015	3,80-7,90	7,9	13,50	15,11	0,55	20,45	13,46	10,80	35,31	26,04	28,45

**NOTE 1:** Grip range can be affected by parent material density and actual hole size. AVK suggests trial installations to determine optimum grip. **NOTE 2:** Additional UNF fine threads are available. Contact AVK for details. **NOTE 3:** Additional grip lengths are available in certain thread sizes. Contact AVK for details. \* Dimensions in minimum grip condition.

# PART NUMBERING SYSTEM

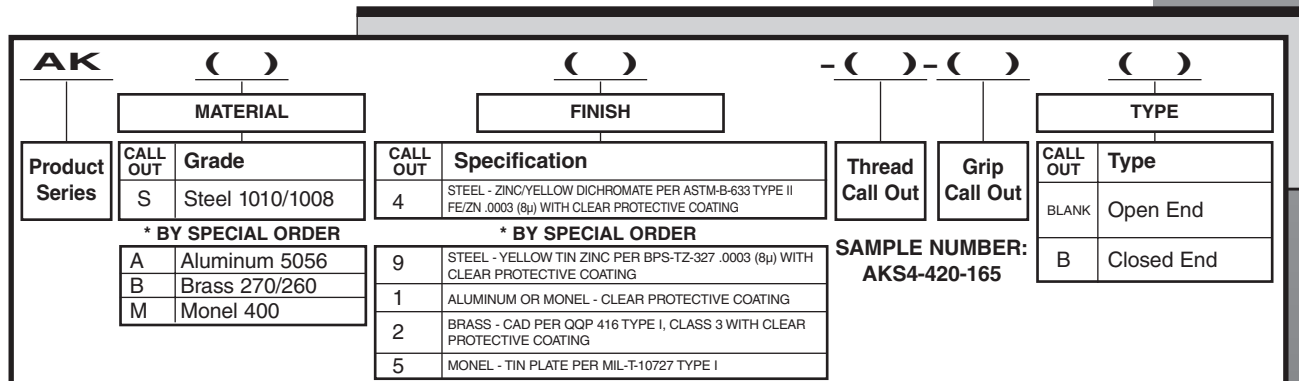

\* Special order items are subject to minimum order requirements. Contact AVK for details.

For air tool selection see pages 28 and 30

## A-H SERIES INSERT PROFILE

The **A-H Series Insert** features a radius corner hex body. When installed into a corresponding hex hole, the radius corners of the A-H Series Insert expand and fill the hole corners providing exceptional resistance to spinning in the panel. The A-H Series is designed to be used with Grade 5 or Metric Class 8.8/9.8 mating screws.

The A-H Series Insert can be installed using AVK's ARO brand pneumatic tools or AVK's SPP<sup>TM</sup> pneumatic/hydraulic tooling. These tools can be located at any position on your assembly line. The A-H Series Insert can be installed either before or after finish.



## SPINWALL TECHNOLOGY<sup>TM</sup>

### HOW HOLE FILL WORKS FOR YOU

As the A-H Series is installed, the radius cornered hex body expands **FILLING THE HOLE**. This feature provides exceptional torque strength and vibration resistance.

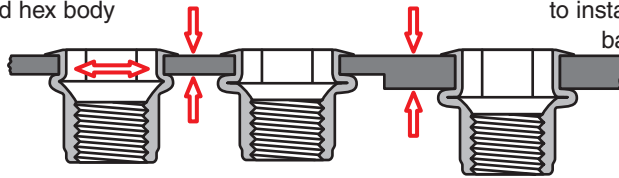

The installation tool then continues to install the insert forming a backside flange even in multiple or variable thickness materials **—WITHOUT ADJUSTMENT.**

## DESIGN BENEFITS

- ◆ **EXCEPTIONAL** resistance to spinning in the panel is achieved as the A-H Series' hex body expands **FILLING THE HOLE**.
- ◆ **AVOID STRESS FRACTURES** of your material and prolong punch and die life by specifying a radius corner in your hex hole. This is possible when using the A-H Series radius hex body insert.
- ◆ **QUALITY INSTALLATIONS** even in variable thickness materials are assured by AVK's spin/spin ARO pneumatic tools and our SPP<sup>TM</sup> pneumatic/hydraulic tools.
- ◆ **SUPERIOR THREAD STRENGTH** is provided due to our internal rolled thread manufacturing process.
- ◆ **THREADS GAUGE** before and after installation due to the increased cross-sectional thickness of the thread area. Thread dilation is prevented.
- ◆ **INVENTORY REDUCTION** is possible because of the A-H Series' wide grip range capacity. It is 2.5 times greater than conventional rivet nuts.
- ◆ **SUPERIOR CORROSION RESISTANCE** is provided by our standard zinc/yellow dichromate finish (96 hours, salt spray to white corrosion). For exceptional corrosion protection we offer a tin/zinc alloy finish.
- ◆ **AVAILABLE IN STEEL.**

## ADDITIONAL DESIGN TYPES

### CLOSED END

Thread area is enclosed eliminating leakage past the threads from either side of the application. See page 15.



### SEALED HEAD

A PVC foam seal is bonded to the underside of the head and when installed provides a weathertight seal. Also available in the closed end version. See page 19 for important grip information.



### OPEN END

Stainless Steel Hex body insert available in specific thread ranges only. Please contact your AVK Sales Representative for more information.



# UNIFIED (INCH) AND METRIC THREAD SIZES

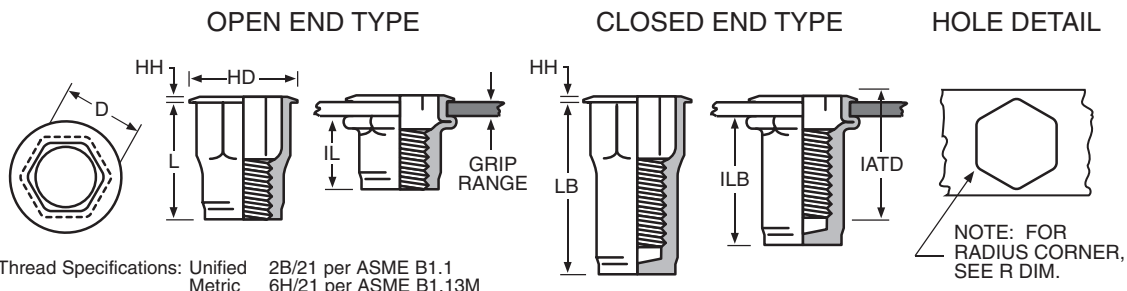

Thread Specifications: Unified 2B/21 per ASME B1.1  
Metric 6H/21 per ASME B1.13M

THREAD SIZE	THREAD CALL OUT	GRIP RANGE	GRIP CALL OUT	HOLE SIZE (ACROSS FLATS) +.004 -.000	HD ±.010 ±.025*	HH ±.003	L ±.015	D MAX.	IL MAX.	LB ±.015	ILB MAX.	IATD** MAX.	R MAX.
6-32 UNC	632	.020-.080	80	.250	.375	.027	.385	.249	.295	.740	.640	.575	.015
6-32 UNC	632	.080-.130	130	.250	.375	.027	.435	.249	.295	.740	.580	.640	.015
8-32 UNC	832	.020-.080	80	.250	.375	.027	.385	.249	.295	.740	.640	.575	.015
8-32 UNC	832	.080-.130	130	.250	.375	.027	.435	.249	.295	.740	.580	.640	.015
10-24 UNC	1024	.020-.130	130	.281	.390	.027	.435	.280	.275	1.030	.845	.695	.020
10-24 UNC	1024	.130-.225	225	.281	.390	.027	.535	.280	.275	1.030	.735	.805	.020
10-32 UNF	1032	.020-.130	130	.281	.390	.027	.435	.280	.275	1.030	.845	.695	.020
10-32 UNF	1032	.130-.225	225	.281	.390	.027	.535	.280	.275	1.030	.735	.805	.020
1/4-20 UNC	420	.027-.165	165	.375	.510	.030	.585	.374	.400	1.190	1.015	.945	.040
1/4-20 UNC	420	.165-.260	260	.375	.510	.030	.685	.374	.400	1.190	.915	1.085	.040
5/16-18 UNC	518	.027-.150	150	.500	.655*	.035	.685	.499	.530	1.445	1.235	1.045	.040
5/16-18 UNC	518	.150-.312	312	.500	.655*	.035	.845	.499	.515	1.445	1.220	1.170	.040
3/8-16 UNC	616	.027-.150	150	.500	.655*	.035	.685	.499	.530	1.445	1.235	1.045	.040
3/8-16 UNC	616	.150-.312	312	.500	.655*	.035	.845	.499	.515	1.445	1.220	1.170	.040

THREAD SIZE	THREAD CALL OUT	GRIP RANGE	GRIP CALL OUT	HOLE SIZE (ACROSS FLATS) +0,10 -0,00	HD ±0,25 ±0,64*	HH ±0,08	L ±0,38	D MAX.	IL MAX.	LB ±0,38	ILB MAX.	IATD** MAX.	R MAX.
M4 x 0,7 ISO	470	0,50-2,00	2,0	6,35	9,53	0,68	9,78	6,35	7,49	18,80	16,26	14,61	,38
M4 x 0,7 ISO	470	2,00-3,30	3,3	6,35	9,53	0,68	11,05	6,35	7,49	18,80	14,73	16,26	,38
M5 x 0,8 ISO	580	0,50-3,30	3,3	7,14	9,91	0,68	11,05	7,10	6,99	26,16	21,46	17,65	,50
M5 x 0,8 ISO	580	3,30-5,70	5,7	7,14	9,91	0,68	13,59	7,10	6,99	26,16	18,67	20,45	,50
M6 x 1,0 ISO	610	0,70-4,20	4,2	9,53	12,96	0,76	14,86	9,50	10,16	30,23	25,78	24,00	1,0
M6 x 1,0 ISO	610	4,20-6,60	6,6	9,53	12,96	0,76	17,40	9,50	10,16	30,23	23,24	27,56	1,0
M8 x 1,25 ISO	8125	0,70-3,8	3,8	12,70	16,64*	0,89	17,40	12,70	13,46	36,70	31,37	26,54	1,0
M8 x 1,25 ISO	8125	3,8-7,90	7,9	12,70	16,64*	0,89	21,46	12,70	13,08	36,70	30,99	29,72	1,0
M10 x 1,5 ISO	1015	0,70-3,8	3,8	12,70	16,64*	0,89	17,40	12,70	13,46	36,70	31,37	26,54	1,0
M10 x 1,5 ISO	1015	3,8-7,90	7,9	12,70	16,64*	0,89	21,46	12,70	13,08	36,70	30,99	29,72	1,0

**NOTE 1:** Grip range can be affected by parent material density and actual hole size. AVK suggests trial installations to determine optimum grip. **NOTE 2:** Available in additional materials and sizes. Contact AVK for details.  
\*\*Dimensions in minimum grip condition.

## PART NUMBERING SYSTEM

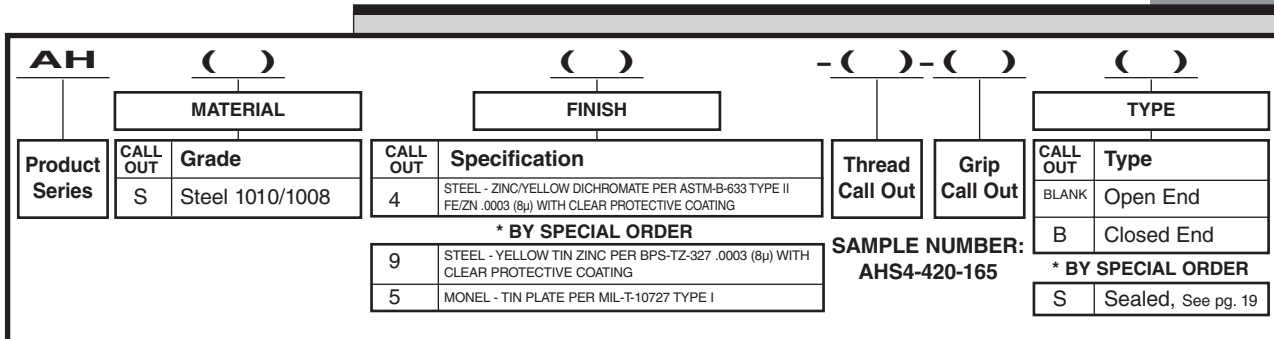

\* Special order items are subject to minimum order requirements. Contact AVK for details.

For air tool selection see pages 28 and 30

## A-R SERIES<sup>TM</sup> INSERT PROFILE

The A-R Series<sup>TM</sup> threaded insert has been designed for use in plastics and thin gauge sheet metal applications where increased pull-out resistance is required.

The A-R Series features a PreSet<sup>TM</sup> slotted body design that when installed folds into four segments gripping the backside of the parent material. This design feature allows the A-R Series to be installed into single, variable or multiple thickness materials using AVK's ARO torque-stall pneumatic tools or AVK's SPP<sup>TM</sup> pneumatic/hydraulic tools.

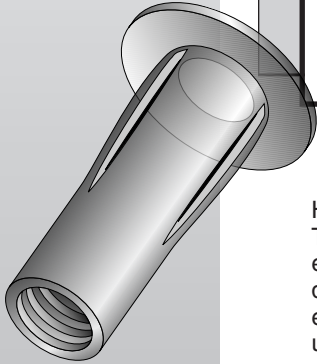

### A-R Series<sup>TM</sup> PreSet<sup>TM</sup> Design

HOW IT WORKS FOR YOU

How it works for you:  
The PreSet<sup>TM</sup> slightly expanded slotted body design of the A-R Series enables it to be installed using torque type tools.

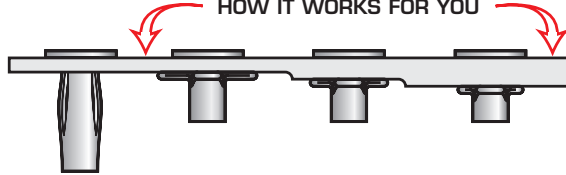

Hand or pneumatic torque tools will install the A-R Series in single, variable or multiple thickness materials.

## DESIGN BENEFITS

- ◆ INSTALLS USING TORQUE stall type tooling due to the slightly expanded slotted body design. This is important when working with plastics that vary in thickness. No adjustment of the tool is necessary when installing the part into variable thickness materials.
- ◆ SUPERIOR CORROSION RESISTANCE because all surfaces of the slotted body are plated. Standard plating is zinc/yellow dichromate finish (96 hours to white corroding). For exceptional corrosion protection we offer a tin/zinc alloy finish.
- ◆ INSTALLS USING HAND WRENCHED TORQUE type tools. Ideal for use in kits and consumer installation applications
- ◆ Superior thread strength due to AVK's internal roll threading process.
- ◆ PROVIDES EXCEPTIONAL pull out resistance in soft plastics or thin sheet metal applications even if holes are hand drilled and oversized.
- ◆ AVAILABLE IN STEEL.

## AIR TOOL SELECTION SPP<sup>TM</sup> TOOL

The A-R has been designed to install with either the SPP Tool or the ARO type tool. The SPP Tool will install the A-R per the suggested grip ranges shown on page 17. See page 33 for SPP tool information.

## AIR TOOL SELECTION ARO<sup>TM</sup> TOOL

The ARO pneumatic tool shown on pages 28 and 29 will install the A-R Series threaded insert. It will affect the published grip range of the part based on the tools' RPM and the density of the parent material. See the chart on page 17 for grip range information. AVK suggests trial installations in the actual application before specifying the optimum ARO tool.

## ADDITIONAL DESIGN TYPES

### A-R STUDS

An A-R blind side, petaled footprint produces exceptional pull-out combined with a stud for component attachment.

Contact AVK for availability.



### SPECIAL HEAD DESIGNS

Special head configurations such as square or wedge head can increase the inserts holding resistance in the parent material.

Contact AVK for availability.



### STRAIGHT BODY DESIGN

A straight body A-R Series<sup>®</sup> insert is ideal for thin sheet metals, tubing & plastic applications where high pull-out is required.

Contact AVK for availability.



# UNIFIED (INCH) AND METRIC THREAD SIZES

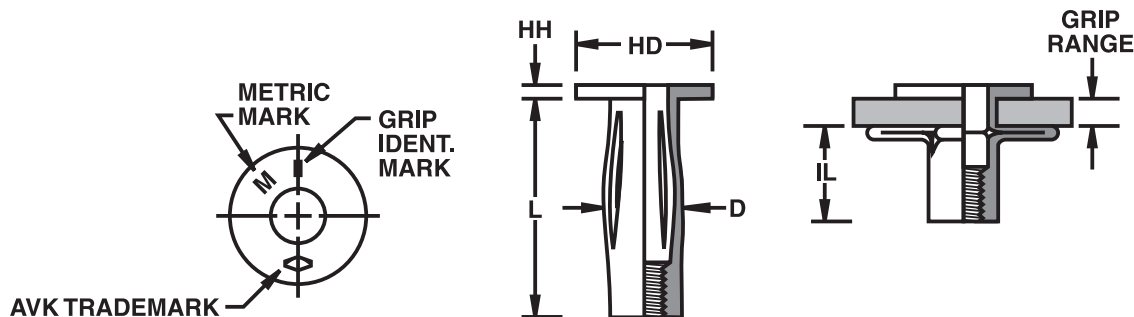

**THREAD CLASS:** Unified 2B/21 per ASME B1.1  
Metric 6H/21 per ASME B1.13M

**MATERIAL:** S=Steel C1010/1008

**PLATING:** 4=Yellow Zinc Plate per ASTM-B633TYII, FE/ZN 8, .0003 (8μ) with clear protective coating

THREAD SIZE	THREAD CALL OUT	GRIP RANGE	GRIP CALL OUT	HOLE SIZE	HD	HH'	L	D	IL MAX	GRIP ID MARK
1/4-20 UNC	420	.020-.280	.280	.390 .396	.645 .610	.063 .053	1.015 .985	.382 .368	.520	Blank
1/4-20 UNC	420	.280-.500	.500	.390 .396	.645 .610	.063 .053	1.249 1.219	.382 .368	.520	1 Rad
5/16-18 UNC	518	.020-.280	.280	.500 .506	.770 .740	.067 .057	1.156 1.126	.495 .490	.775	Blank
5/16-18 UNC	518	.280-.500	.500	.500 .506	.770 .740	.067 .057	1.390 1.360	.495 .490	.775	1 Rad
3/8-16 UNC	616	.020-.280	.280	.594 .600	.865 .895	.083 .093	1.205 1.233	.582 .587	.775	Blank
M6x1,0 ISO	610	0,5-7,1	7.1	10,00 10,15	16,38 15,49	1,60 1,35	25,78 25,02	9,8 9,35	13,21	Blank
M6x1,0 ISO	610	7,1-12,7	12.7	10,00 10,15	16,38 15,49	1,60 1,35	31,72 30,96	9,8 9,35	13,21	1 Rad
M8x1,25 ISO	8125	0,5-7,1	7.1	12,70 12,85	19,56 18,80	1,70 1,45	29,63 28,60	12,57 12,47	19,69	Blank
M8x1,25 ISO	8125	7,1-12,7	12.7	12,70 12,85	19,56 18,80	1,70 1,45	35,31 34,54	12,57 12,47	19,69	1 Rad
M10x1,5 ISO	1015	0,5-7,1	7.1	15,09 15,24	22,73 21,97	2,36 2,11	31,32 30,61	14,91 14,78	19,69	Blank

**NOTE 1:** Grip range stated in the dimensional chart above can be achieved using pull type installation tools and may be variable based on hole size and parent material density. AVK recommends trial installations to determine actual grip range in the application. **NOTE 2:** Grip ranges will be less than stated above when using torque type installation tools. Grip range will be affected by the tool RPM speed, stall torque, hole size and parent material density. AVK recommends trial installations to determine actual grip. See page 33 for torque tool selection guidelines.

## PART NUMBERING SYSTEM

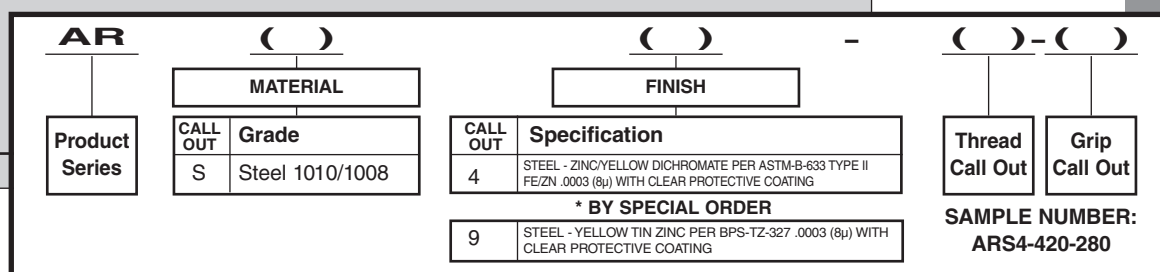

\* Special order items are subject to minimum order requirements. Contact AVK for details.

For air tool selection see pages 33 and 35

# A-L SERIES SEALED HEAD INSERT PROFILE

The A-L Series Sealed Head Insert provides all the features of the standard A-L Series Insert plus the addition of a PVC foam seal that is bonded to the underside head of the insert. This feature provides a weather resistant seal that will withstand 50 PSI - 3.4 BARS of pressure.

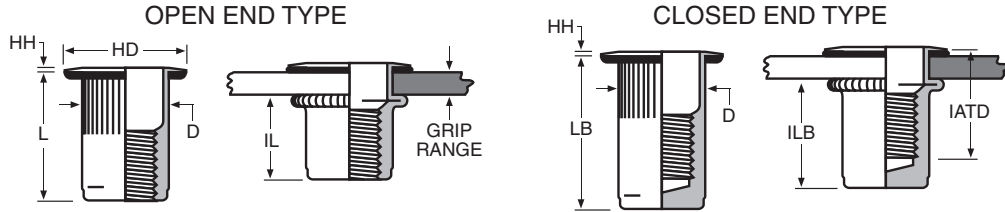

## UNIFIED (INCH) AND METRIC THREAD SIZES

THREAD SIZE	THREAD CALL OUT	GRIP RANGE	GRIP CALL OUT	HOLE SIZE +.006 -.000 (+.015 -.000)	HD ±.010 ±.025* (±.04*)	HH ±.003 (±.008)	L ±.015 (±.038)	D MAX.	IL MAX.	LB ±.015 (±.038)	ILB MAX.	IATD* MAX.
6-32 UNC	632	.020-.060	80	17/64 (.2656)	.390	.030	.420	.265	.305	.740	.640	.610
6-32 UNC	632	.060-.100	130	17/64 (.2656)	.390	.030	.470	.265	.305	.740	.580	.670
8-32 UNC	832	.020-.060	80	17/64 (.2656)	.390	.030	.420	.265	.305	.740	.640	.610
8-32 UNC	832	.060-.100	130	17/64 (.2656)	.390	.030	.470	.265	.305	.740	.580	.670
10-24 UNC	1024	.020-.100	130	19/64 (.2969)	.415	.030	.475	.296	.315	.990	.845	.730
10-24 UNC	1024	.100-.175	225	19/64 (.2969)	.415	.030	.585	.296	.315	.990	.735	.840
10-32 UNF	1032	.020-.100	130	19/64 (.2969)	.415	.030	.475	.296	.315	.990	.845	.730
10-32 UNF	1032	.100-.175	225	19/64 (.2969)	.415	.030	.585	.296	.315	.990	.735	.840
1/4-20 UNC	420	.027-.125	165	25/64 (.3906)	.500	.030	.580	.390	.380	1.190	1.005	.895
1/4-20 UNC	420	.125-.195	260	25/64 (.3906)	.500	.030	.680	.390	.380	1.190	.905	1.035
5/16-18 UNC	518	.027-.115	150	17/32 (.5312)	.685*	.035	.690	.530	.470	1.390	1.175	.995
5/16-18 UNC	518	.115-.250	312	17/32 (.5312)	.685*	.035	.805	.530	.425	1.390	1.025	1.120
3/8-16 UNC	616	.027-.115	150	17/32 (.5312)	.685*	.035	.690	.530	.470	1.390	1.175	.995
3/8-16 UNC	616	.115-.250	312	17/32 (.5312)	.685*	.035	.805	.530	.425	1.390	1.025	1.120
1/2-13 UNC	813	.063-.150	200	11/16 (.6875)	.865*	.047	1.150	.685	.850	2.365	2.070	1.505
1/2-13 UNC	813	.150-.280	350	11/16 (.6875)	.865*	.047	1.300	.685	.850	2.365	1.920	1.505
1/2-13 UNC	813	.280-.400	500	11/16 (.6875)	.865*	.047	1.450	.685	.860	3.365	1.770	1.505
M4x0.7 ISO	470	0.50-1.52	2.0	6.75	9.91	0.76	10.67	6.73	7.75	18.80	16.26	15.49
M4x0.7 ISO	470	1.52-2.54	3.3	6.75	9.91	0.76	11.94	6.73	7.75	18.80	14.73	17.02
M5x0.8 ISO	580	0.50-2.54	3.3	7.60	10.54	0.76	12.07	7.52	8.00	25.15	21.46	18.54
M5x0.8 ISO	580	2.54-4.45	5.7	7.60	10.54	0.76	14.86	7.52	8.00	25.15	18.67	21.34
M6x1.0 ISO	610	0.70-3.17	4.2	10.00	12.70	0.76	14.73	9.91	9.65	30.23	25.53	22.73
M6x1.0 ISO	610	3.17-4.95	6.6	10.00	12.70	0.76	17.27	9.91	9.65	30.23	22.99	26.29
M8x1.25 ISO	8125	0.70-2.92	3.8	13.50	17.40*	0.89	17.53	13.46	11.94	35.31	29.85	25.27
M8x1.25 ISO	8125	2.92-6.35	7.9	13.50	17.40*	0.89	20.45	13.46	10.80	35.31	26.04	28.45
M10x1.5 ISO	1015	0.70-2.92	3.8	13.50	17.40*	0.89	17.53	13.46	11.94	35.31	29.85	25.27
M10x1.5 ISO	1015	2.92-6.35	7.9	13.50	17.40*	0.89	20.45	13.46	10.80	35.31	26.04	28.45
M12x1.75 ISO	12175	1.60-3.81	5.1	17.45	21.97*	1.19	29.21	17.4	21.59	60.07	52.58	38.23
M12x1.75 ISO	12175	3.81-7.11	8.9	17.45	21.97*	1.19	33.02	17.4	21.59	60.07	48.77	38.23
M12x1.75 ISO	12175	7.11-10.16	12.7	17.45	21.97*	1.19	36.83	17.4	21.84	60.07	44.96	38.23

**NOTE 1:** Grip range can be affected by parent material density and actual hole size. AVK suggests trial installations to determine optimum grip. **NOTE 2:** Additional UNF fine thread materials are available. Contact AVK for details. **NOTE 3:** The A-L Series shown on this page incorporates an underhead seal which reduces the standard grip range of the part based on the seal thickness. The grip call out remains based on the standard part for part numbering simplicity.

**NOTE 4:** The PVC foam seal is not recommended for use with petroleum based liquids. \* Dimensions in minimum grip condition.

## PART NUMBERING SYSTEM

<b>AL</b>		<b>( )</b>		<b>( )</b>		<b>- ( ) - ( )</b>		<b>( )</b>	
<b>MATERIAL</b>		<b>FINISH</b>		<b>Thread</b>		<b>Grip</b>		<b>TYPE</b>	
<b>Product Series</b>	<b>CALL OUT</b> S	<b>Grade</b> Steel 1010/1008	<b>CALL OUT</b> 4	<b>Specification</b> STEEL - ZINC/YELLOW DICHROMATE PER ASTM-B-633 TYPE II FE/ZN .003 (6µ) WITH CLEAR PROTECTIVE COATING		<b>Thread Call Out</b>	<b>Grip Call Out</b>	<b>CALL OUT</b> BLANK	<b>Type</b> Open End
				<b>* BY SPECIAL ORDER</b>		<b>SAMPLE NUMBER:</b> ALS4-420-165S		<b>* BY SPECIAL ORDER</b>	
				9 STEEL - YELLOW TIN ZINC PER BPS-TZ-327 .0003 (6µ) WITH CLEAR PROTECTIVE COATING				S Sealed	

\* Special order items are subject to minimum order requirements. Contact AVK for details.

For air tool selection see pages 28 and 30

Thread Specifications: Unified 2B/21 per ASME B1.1 Metric 6H/21 per ASME B1.13M

# A-H SERIES SEALED HEAD INSERT PROFILE

The **A-H Series Sealed Head Insert** provides all the features of the standard A-H Series Insert plus the addition of a PVC foam seal that is bonded to the underside head of the insert. This feature provides a weather resistant seal that will withstand 50 PSI–3.4 bars of pressure.

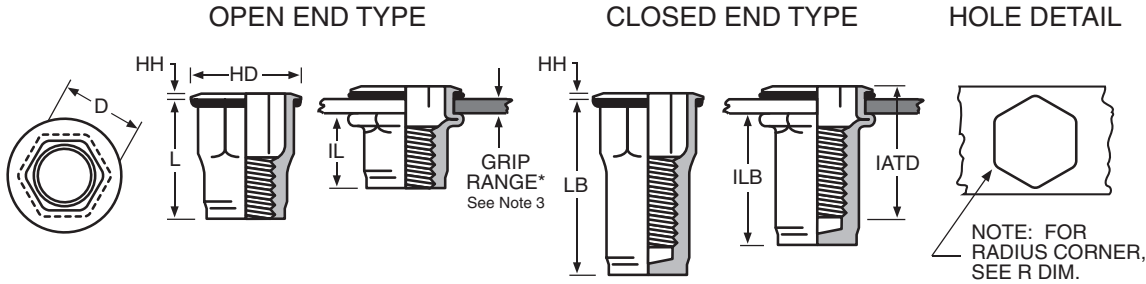

## UNIFIED (INCH) AND METRIC THREAD SIZES

THREAD SIZE	THREAD CALL OUT	GRIP RANGE	GRIP CALL OUT	HOLE SIZE (ACROSS FLATS) +.004 -.000 (+0,10 -0,00)	HD ±.010 ±.025* (±0,25) (±0,64*)	HH ±.003 (±0,08)	L ±.015 (±0,38)	D MAX.	IL MAX.	LB ±.015 (±0,38)	ILB MAX.	IATD** MAX.	R MAX.
6-32 UNC	632	.020-.060	80	.250	.375	.027	.385	.249	.295	.740	.640	.575	.015
6-32 UNC	632	.060-.100	130	.250	.375	.027	.435	.249	.295	.740	.580	.640	.015
8-32 UNC	832	.020-.060	80	.250	.375	.027	.385	.249	.295	.740	.640	.575	.015
8-32 UNC	832	.060-.100	130	.250	.375	.027	.435	.249	.295	.740	.580	.640	.015
10-24 UNC	1024	.020-.100	130	.281	.390	.027	.535	.280	.275	1.030	.845	.695	.020
10-24 UNC	1024	.100-.175	225	.281	.390	.027	.535	.280	.275	1.030	.735	.805	.020
10-32 UNF	1032	.020-.100	130	.281	.390	.027	.435	.280	.275	1.030	.845	.695	.020
10-32 UNF	1032	.100-.175	225	.281	.390	.027	.535	.280	.275	1.030	.735	.805	.020
1/4-20 UNC	420	.027-.125	165	.375	.510	.030	.585	.374	.400	1.190	1.015	.945	.040
1/4-20 UNC	420	.125-.195	260	.375	.510	.030	.685	.374	.400	1.190	.915	1.085	.040
5/16-18 UNC	518	.027-.115	150	.500	.655*	.035	.685	.499	.530	1.445	1.235	1.045	.040
5/16-18 UNC	518	.115-.250	312	.500	.655*	.035	.845	.499	.515	1.445	1.220	1.170	.040
3/8-16 UNC	616	.027-.115	150	.500	.655*	.035	.685	.499	.530	1.445	1.235	1.045	.040
3/8-16 UNC	616	.115-.250	312	.500	.655*	.035	.845	.499	.515	1.445	1.220	1.170	.040
M4x0,7 ISO	470	0,50-1,52	2,0	6,35	9,53	0,68	9,78	6,35	7,49	18,80	16,26	14,61	,38
M4x0,7 ISO	470	1,52-2,54	3,3	6,35	9,53	0,68	11,05	6,35	7,49	18,80	14,73	16,26	,38
M5x0,8 ISO	580	0,50-2,54	3,3	7,14	9,91	0,68	11,05	7,10	6,99	26,16	21,46	17,65	,50
M5x0,8 ISO	580	2,54-4,45	5,7	7,14	9,91	0,68	13,59	7,10	6,99	26,16	18,67	20,45	,50
M6x1,0 ISO	610	0,70-3,17	4,2	9,53	12,96	0,76	14,86	9,50	10,16	30,23	25,78	24,00	1,0
M6x1,0 ISO	610	3,17-4,95	6,6	9,53	12,96	0,76	17,40	9,50	10,16	30,23	23,24	27,56	1,0
M8x1,25 ISO	8125	0,70-2,92	3,8	12,70	16,64*	0,89	17,40	12,70	13,46	36,70	31,37	26,54	1,0
M8x1,25 ISO	8125	2,92-6,35	7,9	12,70	16,64*	0,89	21,46	12,70	13,08	36,70	30,99	29,72	1,0
M10x1,5 ISO	1015	0,70-2,92	3,8	12,70	16,64*	0,89	17,40	12,70	13,46	36,70	31,37	26,54	1,0
M10x1,5 ISO	1015	2,92-6,35	7,9	12,70	16,64*	0,89	21,46	12,70	13,08	36,70	30,99	29,72	1,0

**NOTE 1:** Grip range can be affected by parent material density and actual hole size. AVK suggests trial installations to determine optimum grip. **NOTE 2:** UNF fine threads are available. Contact AVK for details. **NOTE 3:** The A-H Series shown on this page incorporates an underhead seal which reduces the standard grip range of the part based on the seal thickness. The grip call out remains based on the standard part for part numbering simplicity. **NOTE 4:** The PVC foam seal is not recommended for use with petroleum based liquids. \*Dimensions in minimum grip condition.

## PART NUMBERING SYSTEM

<b>AH</b>	( )	( )	- ( ) - ( )	( )
	<b>MATERIAL</b>		<b>FINISH</b>	<b>TYPE</b>
<b>Product Series</b>	<b>CALL OUT</b> S	<b>Grade</b> Steel 1010/1008	<b>CALL OUT</b> 4	<b>Specification</b> STEEL - ZINC/YELLOW DICHROMATE PER ASTM-B-633 TYPE II FE/ZN .0003 (8µ) WITH CLEAR PROTECTIVE COATING
				<b>Thread Call Out</b>
				<b>Grip Call Out</b>
				<b>CALL OUT</b> BLANK
				<b>Type</b> Open End
				B
				Closed End
				S
				Sealed

**\* BY SPECIAL ORDER**  
9 STEEL - YELLOW TIN ZINC PER BPS-TZ-327 .0003 (8µ) WITH CLEAR PROTECTIVE COATING

**SAMPLE NUMBER:** AHS4-420-165S

**\* BY SPECIAL ORDER**

\* Special order items are subject to minimum order requirements. Contact AVK for details.

For air tool selection see pages 28 and 30

Thread Specifications: Unified 2B/21 per ASME B1.1 Metric 6H/21 per ASME B1.13M

## A-S SERIES STUD PROFILE

The **A-S Series Stud** offers a unique design advantage in that once installed, a threaded stud is left protruding from the workpiece. Component parts can be located on the stud until final assembly is accomplished with a mating nut. The A-S series is an ideal alternative to clinch or weld studs. The A-S Series is designed to be used with Grade 5 or Metric Class 8.8/9.8 non thread locking type nuts.

The A-S Series Stud is installed using AVK's ARO brand pneumatic tools or AVK's SPP<sup>TM</sup> pneumatic/hydraulic tools. These tools can be located at any position on your assembly line. The A-S Series Stud can be installed either before or after finish.

### SPINWALL TECHNOLOGY<sup>TM</sup>

#### HOW HOLE FILL WORKS FOR YOU

As the A-S Series is installed, the knurled body expands 360° **FILLING THE HOLE.** This feature provides exceptional torque strength and vibration resistance.

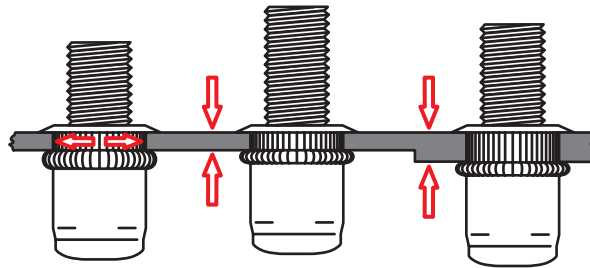

The installation tool then continues to install the stud forming a backside flange even in variable thickness material—**WITHOUT ADJUSTMENT.**

## DESIGN BENEFITS

- ◆ **PROTRUDING STUD** allows component parts to be located on the stud until final assembly is accomplished with a mating nut.
- ◆ **EXCEPTIONAL TORQUE STRENGTH** is achieved as the stud's knurled body expands **FILLING THE HOLE.**
- ◆ **QUALITY INSTALLATIONS** even in variable thickness materials are assured by AVK's spin/spin ARO pneumatic or AVK's SPP pneumatic/hydraulic tools.
- ◆ **ELIMINATE PAINT MASKING** procedures as required with weld or clinch studs. The A-S Series Stud can be installed after painting.
- ◆ **SUPERIOR CORROSION RESISTANCE** is provided by our standard zinc/yellow dichromate finish (96 hours. salt spray to white corrosion). Alternative finishes are available.
- ◆ **AVAILABLE** in Steel 1010/1008 shell - Steel 1038 threaded stud.

## ADDITIONAL DESIGN TYPES

### SEALED HEAD

A PVC foam seal is bonded to the underside of the head and when installed provides a weathertight seal. Note that the addition of a seal reduces the parts grip range. Contact AVK for a sales drawing.

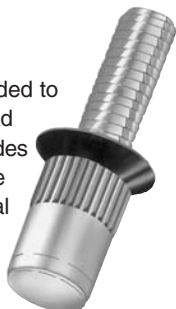

### WEDGE HEAD

The addition of wedges under the head provides even greater torque capability, especially in soft or thin materials, and is excellent for electrical grounding applications. Contact AVK for a sales drawing.



### HEX BODY

The hex shell offers exceptional resistance to spinning once installed. Also available in full body hex version. Contact your sales representative for more information.





# UNIFIED (INCH) AND METRIC THREAD SIZES

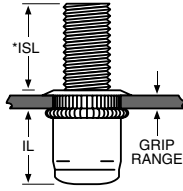
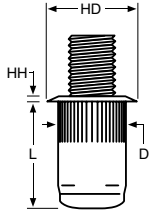

\* NOTE: The ISL Dimension shown below is the height of the installed stud at max grip. The height of the stud will increase if it is installed into thinner material. To calculate actual ISL use this formula: **Max grip – actual grip + ISL = Actual ISL**

Thread Specifications: Unified 2A/21 per ASME B1.1  
Metric 6G/21 per ASME B1.13M

THREAD SIZE	THREAD CALL OUT	GRIP RANGE	GRIP CALL OUT	STUD LENGTHS			HOLE SIZE +.006 -.000	HD ±.010 ±.025*	HH ±.003	L ±.020	D MAX.	IL MAX.
				ISL CALL OUT	ISL CALL OUT	ISL CALL OUT						
6-32 UNC	632	.020-.080	80	.500	.625	.750	17/64 (.2656)	.390	.030	.485	.265	.360
				500	625	750						
6-32 UNC	632	.080-.130	130	.450	.575	.700	17/64 (.2656)	.390	.030	.535	.265	.360
				450	575	700						
8-32 UNC	832	.020-.080	80	.500	.625	.750	17/64 (.2656)	.390	.030	.485	.265	.360
				500	625	750						
8-32 UNC	832	.080-.130	130	.450	.575	.700	17/64 (.2656)	.390	.030	.535	.265	.360
				450	575	700						
10-24 UNC	1024	.020-.130	130	.500	.625	.750	19/64 (.2969)	.415	.030	.545	.296	.380
				500	625	750						
10-24 UNC	1024	.130-.225	225	.405	.530	.655	19/64 (.2969)	.415	.030	.655	.296	.380
				405	530	655						
10-32 UNF	1032	.020-.130	130	.500	.625	.750	19/64 (.2969)	.415	.030	.545	.296	.380
				500	625	750						
10-32 UNF	1032	.130-.225	225	.405	.530	.655	19/64 (.2969)	.415	.030	.655	.296	.380
				405	530	655						
1/4-20 UNC	420	.027-.165	165	.625	.8125	1.000	25/64 (.3906)	.500	.030	.670	.390	.465
				625	8125	1000						
1/4-20 UNC	420	.165-.260	260	.530	.7175	.905	25/64 (.3906)	.500	.030	.770	.390	.465
				530	7175	905						
5/16-18 UNC	518	.027-.150	150	.625	.875	1.125	17/32 (.5312)	.685*	.035	.810	.530	.600
				625	875	1125						
5/16-18 UNC	518	.150-.312	312	.463	.713	.963	17/32 (.5312)	.685*	.035	.925	.530	.555
				463	713	963						
3/8-16 UNC	616	.027-.150	150	.750	1.000	1.250	17/32 (.5312)	.685*	.035	.810	.530	.600
				750	1000	1250						
3/8-16 UNC	616	.150-.312	312	.588	.838	1.088	17/32 (.5312)	.685*	.035	.925	.530	.535
				588	838	1088						

THREAD SIZE	THREAD CALL OUT	GRIP RANGE	GRIP CALL OUT	STUD LENGTHS			HOLE SIZE +0,15 -0,00	HD ±0,25 ±0,64*	HH ±0,08	L ±0,50	D MAX.	IL MAX.
				ISL CALL OUT	ISL CALL OUT	ISL CALL OUT						
M4x0,7 ISO	470	0,50-2,00	2.0	12,0	15,0	20,0	6,75	9,91	0,76	12,32	6,73	9,15
				12	15	20						
M4x0,7 ISO	470	2,00-3,30	3.3	10,7	13,7	18,7	6,75	9,91	0,76	13,59	6,73	9,15
				10,7	13,7	18,7						
M5x0,8 ISO	580	0,50-3,30	3.3	12,0	15,0	20,0	7,60	10,54	0,76	13,84	7,52	9,65
				12	15	20						
M5x0,8 ISO	580	3,30-5,70	5.7	9,6	12,6	17,6	7,60	10,54	0,76	16,64	7,52	9,65
				9,6	12,6	17,6						
M6x1,0 ISO	610	0,70-4,20	4.2	15,0	20,0	25,0	10,00	12,70	0,76	17,02	9,91	11,81
				15	20	25						
M6x1,0 ISO	610	4,20-6,60	6.6	12,6	17,6	22,6	10,00	12,70	0,76	19,56	9,91	11,81
				12,6	17,6	22,6						
M8x1,25 ISO	8125	0,70-3,8	3.8	16,0	22,0	28,0	13,50	17,40*	0,89	20,57	13,46	15,24
				16	22	28						
M8x1,25 ISO	8125	3,8-7,90	7.9	11,9	17,9	23,9	13,50	17,40*	0,89	23,50	13,46	14,10
				11,9	17,9	23,9						
M10x1,5 ISO	1015	0,70-3,8	3.8	20,0	25,0	30,0	13,50	17,40*	0,89	20,57	13,46	15,24
				20	25	30						
M10x1,5 ISO	1015	3,8-7,90	7.9	15,9	20,9	25,9	13,50	17,40*	0,89	23,50	13,46	13,60
				15,9	20,9	25,9						

NOTE 1: Grip range can be affected by parent material density and actual hole size. AVK suggests trial installations to determine optimum grip. NOTE 2: Additional UNF fine threads are available. Contact AVK for details. \* Dimensions in maximum grip condition.

## PART NUMBERING SYSTEM

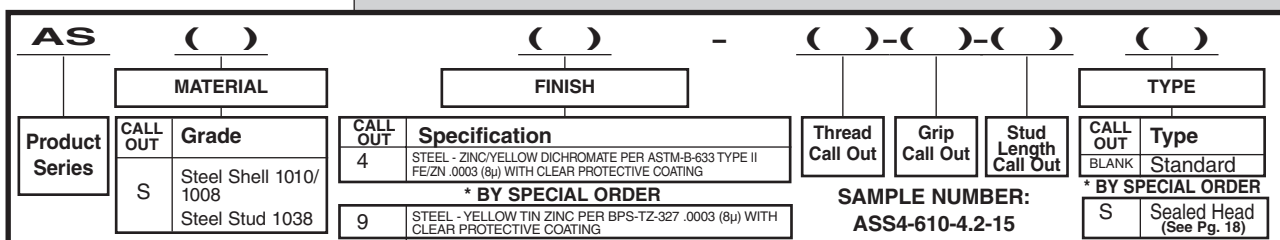

\* Special order items are subject to minimum order requirements. Contact AVK for details.

For air tool selection see page 32

## A-T SERIES INSERT PROFILE

The **A-T Series Insert** is unique in that it can be installed into most any material above .030/.76 mm in thickness. As the A-T Series is installed, the threaded portion is completely swaged 360° into the sleeve portion and the hole. This permits the A-T Series to be used with Grade 8/Metric 12.9 mating screws.

The A-T Series Insert is installed using lightweight, handheld pneumatic ARO tools that can be located at any position in your product's assembly sequence. The A-T Series Insert can be installed either prior to or after finish.



### 360° SWAGING HOW IT WORKS FOR YOU

As the A-T Series Insert is installed, the threaded nut portion is drawn into the upper sleeve portion.

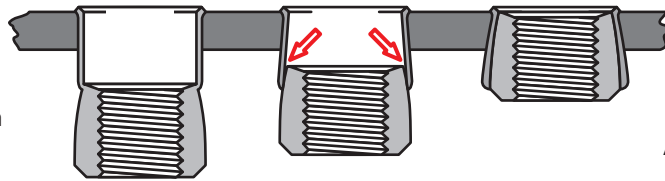

As this occurs, a 360° swaging action takes place anchoring the A-T Series in the parent material.

## DESIGN BENEFITS

- ◆ **REDUCED OVERALL LENGTH** of the installed A-T Series Insert allows it to be used in limited clearance applications.
- ◆ **QUALITY INSTALLATIONS** even in variable thickness materials are assured by our spin/spin torque stall tools (featured on page 29).
- ◆ **INVENTORY REDUCTION** is possible because one A-T Series Insert will work in any thickness
- ◆ **INSTALLS INTO MOST ANY MATERIAL** with a thickness over .030/.76 mm.
- ◆ **CAN BE USED WITH GRADE 8/METRIC CLASS 12.9 SCREWS** due to the A-T Series high shear load capability.
- ◆ **AVAILABLE** in Steel, Aluminum, Brass and Series 304 Stainless Steel are available by special order. Contact AVK for details.

## ADDITIONAL DESIGN TYPES

### CLOSED END

Thread area is enclosed eliminating leakage past the threads from either side of the application. See page 23.



## JOINT DESIGN PRACTICES

AVK recommends that the mating part comes in contact with the head of the A-T Series Insert. If a gap or clearance hole exists between the mating part and the A-T Series Insert, the threaded nut portion may rotate or pull through the parent material.

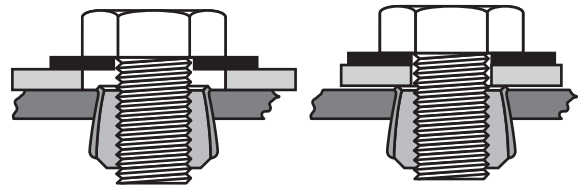

# UNIFIED (INCH) AND METRIC THREAD SIZES

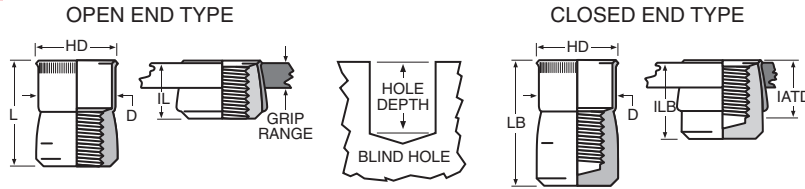

THREAD SIZE	THREAD CALL OUT	HD ±.005	L ±.015	D MAX.	IL MAX.	LB ±.015	ILB MAX.	IATD** MAX.	HOLE DEPTH MIN.
4-40 UNC	440	.211	.370	.1875	.205	.660	.495	.395	.400
6-32 UNC	632	.240	.370	.2185	.205	.675	.505	.410	.400
8-32 UNC	832	.269	.370	.2495	.205	.675	.505	.410	.400
10-24 UNC	1024	.306	.370	.2805	.205	.685	.520	.385	.400
10-32 UNF	1032	.306	.370	.2805	.205	.685	.520	.385	.400
1/4-20 UNC	420	.400	.515	.3745	.275	1.005	.760	.615	.540
5/16-18 UNC	518	.528	.615	.4995	.325	1.065	.770	.630	.640
3/8-16 UNC	616	.588	.745	.5615	.390	1.450	1.095	.890	.770
1/2-13 UNC	813	.800	.935	.7485	.485	NA	NA	NA	.960

\*\* Dimensions in minimum grip condition. Additional UNF thread sizes available. Contact AVK for details.

THREAD SIZE	THREAD CALL OUT	HD ±0,13	L ±0,38	D MAX.	IL MAX.	LB ±0,38	ILB MAX.	IATD** MAX.	HOLE DEPTH MIN.
M3x0,5 ISO	350	5,36	9,40	4,76	5,21	16,77	12,57	10,03	10,16
M4x0,7 ISO	470	6,83	9,40	6,34	5,21	17,15	12,83	10,41	10,16
M5x0,8 ISO	580	7,77	9,40	7,12	5,21	17,40	13,21	9,78	10,16
M6x1,0 ISO	610	10,16	13,08	9,51	6,99	25,53	19,30	15,62	13,72
M8x1,25 ISO	8125	13,41	15,62	12,69	8,26	27,05	19,56	16,00	16,26
M10x1,5 ISO	1015	14,94	18,92	14,26	9,91	36,83	27,81	22,61	19,56
M12x1,75 ISO	12175	20,32	23,75	19,01	12,32	NA	NA	NA	24,38

\*\* Dimensions in minimum grip condition.

# HOLE SIZE / MATERIAL THICKNESS CHART

Installation hole size for the A-T Series Insert is determined by the parent material's thickness and density. The thicker the material the larger the hole required to allow full 360° installation swaging. The application should be tested before hole size is specified.

THREAD SIZE	.030-.090 MAT. THICKNESS		.091-.124 MAT. THICKNESS		.125-.186 MAT. THICKNESS		.187-OVER MAT. THICKNESS	
	DRILL SIZE	DECIMAL	DRILL SIZE	DECIMAL	DRILL SIZE	DECIMAL	DRILL SIZE	DECIMAL
4-40 UNC	3/16	.1875	#10	.1935	#10	.1935	#9	.1960
6-32 UNC	7/32	.2188	#2	.2210	#1	.2280	#1	.2280
8-32 UNC	1/4	.2500	"F"	.2570	17/64	.2656	17/64	.2656
10-24 UNC	9/32	.2812	"L"	.2900	"L"	.2900	19/64	.2969
10-32 UNF	9/32	.2812	"L"	.2900	"L"	.2900	19/64	.2969
1/4-20 UNC	3/8	.3750	3/8	.3750	"W"	.3860	25/64	.3906
5/16-18 UNC	1/2	.5000	1/2	.5000	33/64	.5156	33/64	.5156
3/8-16 UNC	9/16	.5625	9/16	.5625	37/64	.5781	37/64	.5781
1/2-13 UNC	3/4	.7500	49/64	.7656	25/32	.7810	51/64	.7970

THREAD SIZE	0,76-2,29 MAT. THICKNESS		2,31-3,15 MAT. THICKNESS		3,17-4,72 MAT. THICKNESS		4,72-OVER MAT. THICKNESS	
	DRILL SIZE	DECIMAL	DRILL SIZE	DECIMAL	DRILL SIZE	DECIMAL	DRILL SIZE	DECIMAL
M3x0,5 ISO	4,75	.1875	4,90	.1935	4,90	.1935	4,97	.1960
M4x0,7 ISO	6,35	.2500	6,52	.2570	6,74	.2656	6,74	.2656
M5x0,8 ISO	7,14	.2812	7,36	.2900	7,36	.2900	7,54	.2969
M6x1,0 ISO	9,52	.3750	9,52	.3750	9,80	.3860	9,92	.3906
M8x1,25 ISO	12,70	.5000	12,70	.5000	13,09	.5156	13,09	.5156
M10x1,5 ISO	14,28	.5625	14,28	.5625	14,68	.5781	14,68	.5781
M12x1,75 ISO	19,05	.7500	19,44	.7656	19,83	.7810	20,24	.7970

**FINISH:** The standard specified finishes for the A-T Series Insert are cadmium and tin. Alteration to these finishes will reduce performance. **\*THREAD CLASS:** The A-T Series Insert's internal threads are manufactured oversized to compensate for resulting thread portion shrinkage during the installation swaging process. They are not gaugeable prior to or after installation but will be compatible with Class 2A/3A or 6g screws after installation.

All materials for the A-T Series are plated cadmium or tin and look similar. Radial grooves are machined into the part for material identification.

**MATERIAL TYPE IDENTIFICATION GROOVES**

NONE .....STEEL    2 .....BRASS  
1 .....STAINLESS    3 .....ALUMINUM

# PART NUMBERING SYSTEM

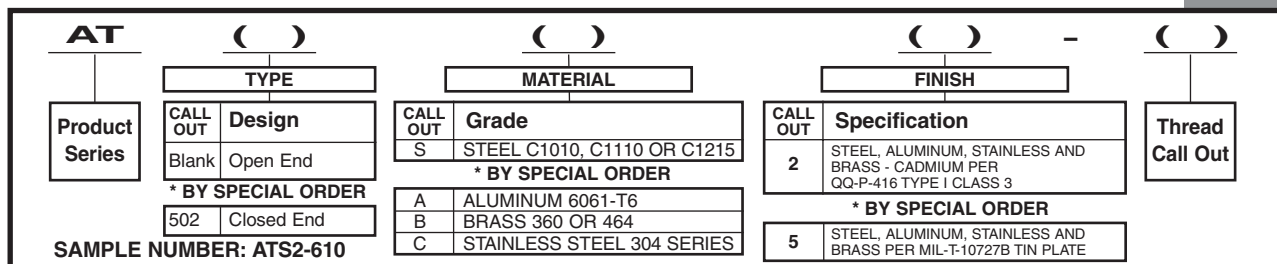

\* Special order items are subject to minimum order requirements. Contact AVK for details.

For air tool selection see page 31

# A-W SERIES INSERT PROFILE

The **A-W Series Insert** can be installed into most any material softer than itself that is thicker than .062/1,57. The A-W Series provides exceptional shear strength and pull out in fiberglass and plywoods. The brass A-W Series Insert is particularly useful for the fiberglass boat industry.

The A-W Series Insert is installed using lightweight, handheld pneumatic tools that can be located at any position in your product's assembly sequence. The A-W Series Insert can be installed either prior to or after finish.

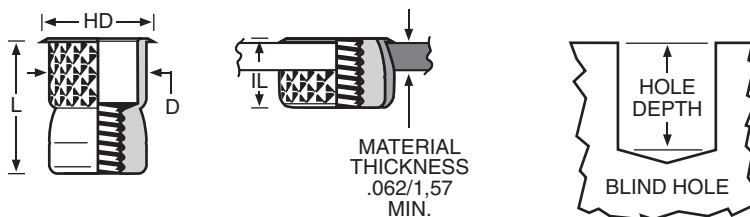

## UNIFIED (INCH) AND METRIC THREAD

SEE THREAD CLASS NOTE \*

THREAD SIZE	THREAD CALL OUT	HOLE SIZE +.005 -.000 (+0,13 -0,00)	HD ±.005 (±0,13)	L ±.015 (±0,38)	D MAX.	IL MAX.	HOLE DEPTH MIN.
6-32 UNC	632	15/64 (.234)	.255	.370	.233	.205	.400
8-32 UNC	832	17/64 (.266)	.285	.370	.264	.205	.400
10-24 UNC	1024	19/64 (.297)	.320	.370	.295	.205	.400
10-32 UNF	1032	19/64 (.297)	.320	.370	.295	.205	.400
1/4-20 UNC	420	25/64 (.391)	.415	.515	.389	.275	.540
5/16-18 UNC	518	17/32 (.531)	.550	.615	.528	.325	.640
3/8-16 UNC	616	19/32 (.594)	.615	.740	.590	.390	.770
M4x0,7 ISO	470	6,75	7,24	9,40	6,71	5,21	10,16
M5x0,8 ISO	580	7,54	8,13	9,40	7,50	5,21	10,16
M6x1,0 ISO	610	9,92	10,54	13,08	9,88	6,99	13,72
M8x1,25 ISO	8125	13,49	13,97	15,62	13,41	8,26	16,26
M10x1,5 ISO	1015	15,00	15,62	18,80	14,99	9,91	19,56

**NOTE 1:** Additional UNF thread sizes available

**NOTE 2: HOLE SIZE:** The A-W Series Insert hole size will be dependent on parent material density. Experimentation is required for optimum performance.

**NOTE 3: FINISH:** The standard specified finishes for the A-W Series Insert are cadmium and tin. Alteration to these finishes will reduce performance.

**\*THREAD CLASS:** The A-W Series Insert's internal threads are manufactured oversized to compensate for resulting thread portion shrinkage during the installation swaging process. They are not gaugeable prior to or after installation but will be compatible with Class 2A/3A or 6g screws after installation.

All materials for the A-W Series are plated cadmium and look similar. Radial grooves are machined into the part for material identification.

### MATERIAL TYPE IDENTIFICATION GROOVES

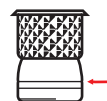

NONE — STEEL  
2 — BRASS

## PART NUMBERING SYSTEM

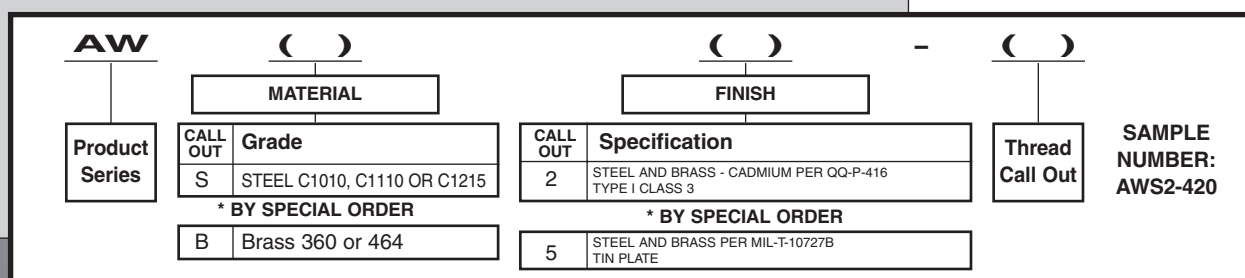

\* Special order items are subject to minimum order requirements. Contact AVK for details.

For air tool selection see page 31

# A-O SERIES PROFILE

The **A-O Series Insert** features a reduced profile head design which is similar to the superior A-K Series Insert. It also has a smaller body diameter than the A-K Series Insert. The A-O Series Insert can be specified when the application design parameters require a smaller hole or closer hole to edge tolerances.

The A-O Series can be installed with AVK's ARO brand pneumatic tools or AVK's SPP™ pneumatic/hydraulic tools. These tools can be located at any position on your assembly line. The A-O Series can be installed either prior to or after finish further enhancing its flexibility in your manufacturing environment.

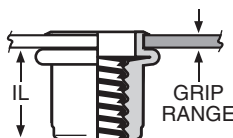
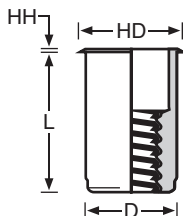

Thread Specifications: Unified 2B/21 per ASME B1.1  
Metric 6H/21 per ASME B1.13M

## UNIFIED (INCH) AND METRIC THREAD SIZES

THREAD SIZE	THREAD CALL OUT	GRIP RANGE	GRIP CALL OUT	HOLE SIZE +.006 -.000 (+.015 -0,00)	HD ±.010 (±0,25)	HH ±.003 (±0,08)	L ±.015 (±0,38)	D MAX.	IL MAX.
6-32 UNC	632	.020-.080	80	1/4 (.250)	.295	.018	.385	.249	.315
8-32 UNC	832	.020-.080	80	1/4 (.250)	.295	.018	.385	.249	.315
10-24 UNC	1024	.020-.130	130	9/32 (.2812)	.320	.020	.440	.280	.330
10-32 UNF	1032	.020-.130	130	9/32 (.2812)	.320	.020	.440	.280	.330
1/4-20 UNC	420	.030-.165	165	3/8 (.375)	.425	.022	.580	.374	.440
5/16-18 UNC	518	.040-.200	200	1/2 (.500)	.560	.022	.690	.499	.540
3/8-16 UNC	616	.040-.200	200	1/2 (.500)	.560	.022	.690	.499	.540
M4x0,7 ISO	470	0,50-2,00	2.0	6,4	7,49	0,46	9,78	6,32	8,00
M5x0,8 ISO	580	0,50-3,30	3.3	7,2	8,13	0,51	11,18	7,11	8,38
M6x1,0 ISO	610	0,76-4,20	4.2	9,6	10,80	0,56	14,73	9,50	11,18
M8x1,25 ISO	8125	1,02-5,1	5.1	12,7	14,22	0,56	17,53	12,67	13,72
M10x1,5 ISO	1015	1,02-5,1	5.1	12,7	14,22	0,56	17,53	12,67	13,72

**NOTE 1:** Grip range can be affected by parent material density and actual hole size. AVK suggests trial installations to determine optimum grip. **NOTE 2:** UNF fine threads are available. Contact AVK for details.

## PART NUMBERING SYSTEM

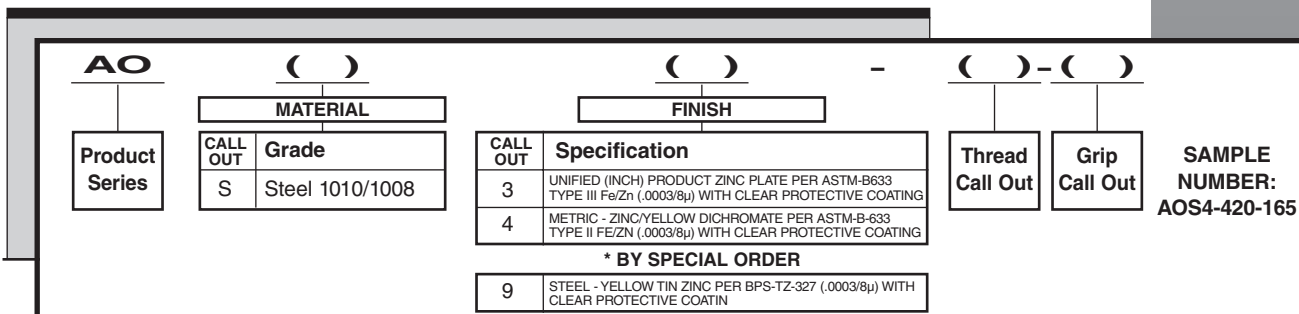

\* Special order items are subject to minimum order requirements. Contact AVK for details.

For air tool selection see pages 28 and 30

# R-N SERIES RIVET NUT PROFILE

**RIVET NUT**  
THREADED INSERT



The **R-N Series Rivet Nut** features a heavy duty head profile and increased wall thickness in the collapse area. This makes the R-N Series ideal for leg leveling applications as shown on page 7.

The R-N Series Rivet Nut can be installed using AVK's SPP™ pneumatic/hydraulic tools or the specific rivet nut tools shown on page 31. The R-N Series Rivet Nut's heavier wall thickness and resulting upset load requires this type of tool be used for installation. The R-N Series can be installed either prior to or after finish.

## COLD FORMING TECHNOLOGY™ HOW IT WORKS FOR YOU

The R-N Series Rivet Nuts are manufactured using state-of-the-art cold forming technology. This provides very precise tolerances. All surfaces of the R-N Series are FORMED, not machined. This provides excellent quality.

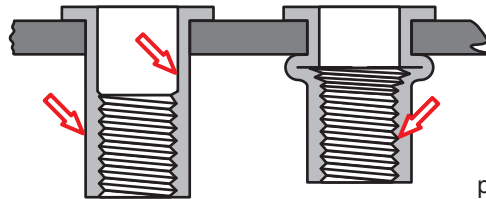



The internal thread of the R-N Series Rivet Nut is roll FORMED not machined. This provides excellent thread strength.

## DESIGN BENEFITS

- ◆ **INCREASED PUSH-OUT LOADS** are achievable in leg leveling applications when using the R-N Series due to its heavy duty head profile and thick wall construction.
- ◆ **SUPERIOR THREAD STRENGTH** is provided due to our internal rolled thread manufacturing process.
- ◆ **SUPERIOR CORROSION RESISTANCE** is provided by our standard cadmium finish (72 hours. salt spray).
- ◆ **UNIFORM INSTALLATION** is guaranteed because of the dimensional tolerances and concentricity tolerances built into our product made possible by our cold forming technology.
- ◆ **AVAILABLE** in steel and aluminum. For additional materials, contact AVK for availability.

## ADDITIONAL DESIGN TYPES

<p><b>CLOSED END</b></p>  <p>Thread area is enclosed eliminating leakage past the threads from either side of the application. Contact AVK for availability.</p>	<p><b>KEYED HEAD</b></p>  <p>An underside of the head "key" projection when placed into a matching "keyed" hole design provides additional torque resistance. Contact AVK for availability.</p>	<p><b>100° COUNTERSUNK HEAD</b></p>  <p>A 100° countersunk head profile when installed into a matching countersunk hole provides a flush installation. Contact AVK for availability.</p>
---	---	---

**FLATHEAD UNIFIED (INCH) AND METRIC THREAD SIZES**

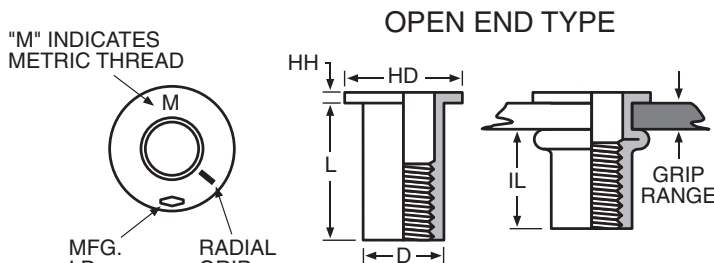

Thread Specifications: Unified MIL-S-7742/ASME-B1.1  
Metric 6H/21 per ASME B1.13M

THREAD SIZE	THREAD CALL OUT	GRIP RANGE	GRIP CALL OUT	I.D. MARK	HOLE SIZE +.003 - .000	HD ±.015	HH NOM.	L ±.015	D +.000 -0.004	IL REF.
4-40 UNC	440	.010-.060	60	BLANK	5/32 (.155)	.270	.025	.345	.155	.230
4-40 UNC	440	.060-.085	85	1-RAD.	5/32 (.155)	.270	.025	.370	.155	.230
4-40 UNC	440	.085-.110	110	2-RAD.	5/32 (.155)	.270	.025	.400	.155	.230
6-32 UNC	632	.010-.075	75	1-RAD.	#12 (.189)	.325	.032	.438	.189	.300
6-32 UNC	632	.075-.120	120	3-RAD.	#12 (.189)	.325	.032	.500	.189	.315
6-32 UNC	632	.120-.160	160	5-RAD.	#12 (.189)	.325	.032	.500	.189	.270
8-32 UNC	832	.010-.075	75	1-RAD.	#2 (.221)	.357	.032	.438	.221	.300
8-32 UNC	832	.075-.120	120	3-RAD.	#2 (.221)	.357	.032	.500	.221	.315
8-32 UNC	832	.120-.160	160	5-RAD.	#2 (.221)	.357	.032	.500	.221	.270
10-32 UNF	1032	.010-.080	80	BLANK	1/4 (.250)	.406	.038	.531	.250	.380
10-32 UNF	1032	.080-.130	130	1-RAD.	1/4 (.250)	.406	.038	.594	.250	.390
10-32 UNF	1032	.130-.180	180	2-RAD.	1/4 (.250)	.406	.038	.641	.250	.390
1/4-20 UNC	420	.020-.080	80	BLANK	Q (.332)	.475	.058	.625	.332	.450
1/4-20 UNC	420	.080-.140	140	1-RAD.	Q (.332)	.475	.058	.687	.332	.450
1/4-20 UNC	420	.140-.200	200	2-RAD.	Q (.332)	.475	.058	.750	.332	.450
5/16-18 UNC	518	.030-.125	125	BLANK	Z (.413)	.665	.062	.750	.413	.505
5/16-18 UNC	518	.125-.200	200	1-RAD.	Z (.413)	.665	.062	.875	.413	.555
5/16-18 UNC	518	.200-.275	275	2-RAD.	Z (.413)	.665	.062	.937	.413	.540
3/8-16 UNC	616	.030-.115	115	BLANK	12.5 mm (.490)	.781	.088	.844	.490	.585
3/8-16 UNC	616	.115-.200	200	1-RAD.	12.5 mm (.490)	.781	.088	.938	.490	.595
3/8-16 UNC	616	.200-.285	285	2-RAD.	12.5 mm (.490)	.781	.088	1.031	.490	.605
1/2-13 UNC	813	.050-.150	150	BLANK	5/8 (.625)	.906	.085	.906	.625	.605
1/2-13 UNC	813	.150-.250	250	1-RAD.	5/8 (.625)	.906	.085	1.031	.625	.630
1/2-13 UNC	813	.250-.350	350	2-RAD.	5/8 (.625)	.906	.085	1.141	.625	.640

THREAD SIZE	THREAD CALL OUT	GRIP RANGE	GRIP CALL OUT	I.D. MARK	HOLE SIZE +0,08 -0,00	HD ±0,38	HH NOM.	L ±0,38	D +0,00 -0,10	IL REF.
M3x0,5 ISO	350	0,25-1,00	1,0	BLANK	3,94	6,68	0,63	8,00	3,93	5,61
M3x0,5 ISO	350	1,00-1,75	1,75	1-RAD.	3,94	6,68	0,63	8,75	3,93	5,61
M3x0,5 ISO	350	1,75-2,50	2,5	2-RAD.	3,94	6,68	0,63	9,50	3,93	5,61
M4x0,7 ISO	470	0,25-2,00	2,0	BLANK	5,60	9,01	0,81	11,00	5,61	7,08
M4x0,7 ISO	470	2,00-3,00	3,0	1-RAD.	5,60	9,01	0,81	12,00	5,61	7,08
M4x0,7 ISO	470	3,00-4,00	4,0	2-RAD.	5,60	9,01	0,81	13,00	5,61	7,08
M5x0,8 ISO	580	0,25-2,00	2,0	BLANK	7,20	11,17	1,22	14,50	7,13	10,09
M5x0,8 ISO	580	2,00-3,50	3,5	1-RAD.	7,20	11,17	1,22	16,00	7,13	10,09
M5x0,8 ISO	580	3,50-5,00	5,0	2-RAD.	7,20	11,17	1,22	17,50	7,13	10,09
M6x1,0 ISO	610	0,75-2,00	2,0	BLANK	8,50	13,43	1,47	15,50	8,43	10,58
M6x1,0 ISO	610	2,00-3,50	3,5	1-RAD.	8,50	13,43	1,47	17,00	8,43	10,58
M6x1,0 ISO	610	3,50-5,00	5,0	2-RAD.	8,50	13,43	1,47	18,50	8,43	10,58
M8x1,25 ISO	8125	1,00-3,00	3,0	BLANK	10,50	16,65	1,57	18,00	10,48	11,83
M8x1,25 ISO	8125	3,00-5,00	5,0	1-RAD.	10,50	16,65	1,57	20,00	10,48	11,83
M8x1,25 ISO	8125	5,00-7,00	7,0	2-RAD.	10,50	16,65	1,57	22,00	10,48	11,83
M10x1,5 ISO	1015	1,00-3,00	3,0	BLANK	12,50	19,50	2,23	20,00	12,44	13,20
M10x1,5 ISO	1015	3,00-5,50	5,5	1-RAD.	12,50	19,50	2,23	22,50	12,44	13,20
M10x1,5 ISO	1015	5,50-8,00	8,0	2-RAD.	12,50	19,50	2,23	25,00	12,44	13,20
M12x1,75 ISO	12175	1,00-3,00	3,0	BLANK	15,50	22,79	2,23	24,00	15,46	16,45
M12x1,75 ISO	12175	3,00-5,50	5,5	1-RAD.	15,50	22,79	2,23	26,50	15,46	16,45
M12x1,75 ISO	12175	5,50-8,00	8,0	2-RAD.	15,50	22,79	2,23	29,00	15,46	16,45

**NOTE 1:** Grip range can be affected by parent material density and actual hole size. AVK suggests trial installations to determine optimum grip. **NOTE 2:** Additional UNF and UNC threads are available. Contact AVK for details. **NOTE 3:** RN Series threads are not gaugeable after installation. **NOTE 4:** Additional grip sizes, materials, head styles and closed end versions are available by special order. Contact AVK for details.

**PART NUMBERING SYSTEM**

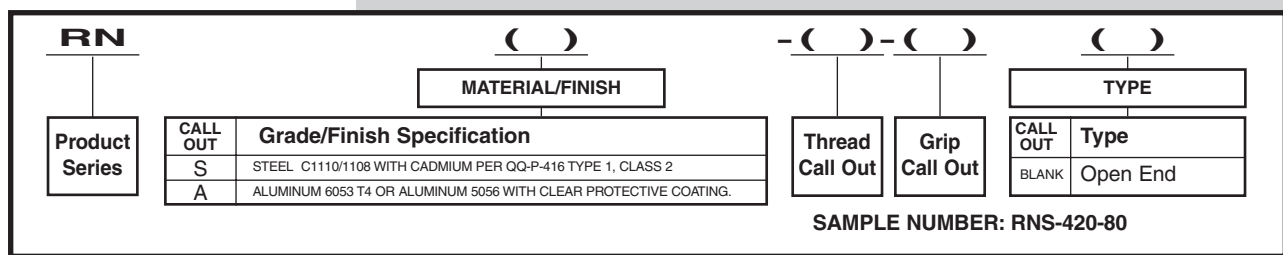

For air tool selection see pages 34 and 37



**PNEUMATIC TOOLS**

PREVIOUS PAGE

PRODUCT INDEX

NEXT PAGE

# AVK PNEUMATIC TOOLS PROFILE

AVK has selected the **ARO Brand Pneumatic Tool** for its ergonomic design and outstanding dependability. The rocker style forward and reverse trigger is easy and comfortable to use. AVK's Quick-Change thread adaption kit assembly allows for easy removal of the tool's nose assembly without the need for wrenches.

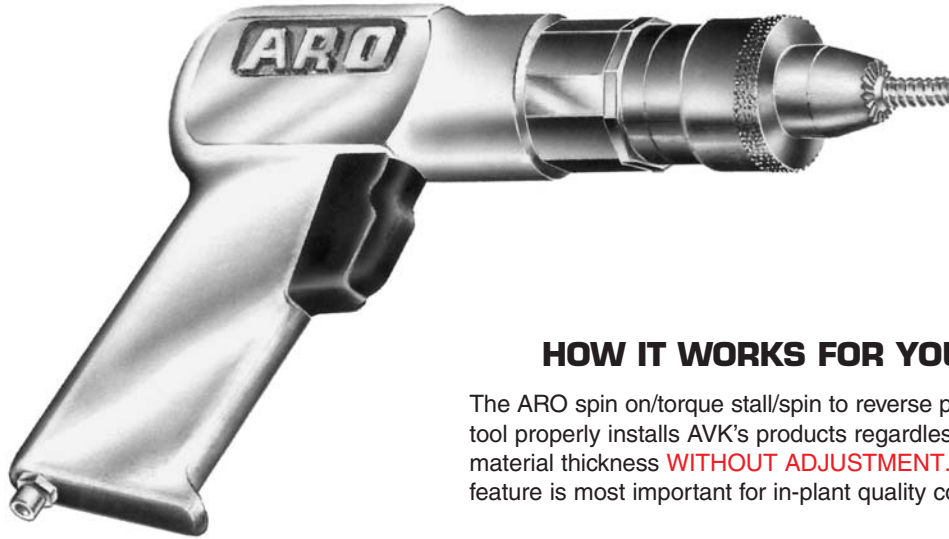

## HOW IT WORKS FOR YOU

The ARO spin on/torque stall/spin to reverse pneumatic tool properly installs AVK's products regardless of material thickness **WITHOUT ADJUSTMENT**. This feature is most important for in-plant quality control.

## DESIGN BENEFITS

- ◆ The AVK ARO tool uses torque to install the AVK product. It needs no adjustment to install the product in variable thickness material.
- ◆ The ergonomic design of the AVK ARO tool makes it feel comfortable to the operator and weighs in at 3 lbs. (1.36 kg).
- ◆ The rocker style trigger is easy to use and minimizes operator fatigue.
- ◆ The knurled nose assembly eliminates any torque "kick" during installation.
- ◆ Preventative maintenance is quick and easy with AVK's patented\* quick-change thread adaption kit. No tools are required to access these parts.
- ◆ The rugged design of the tool casing, its components and the AVK thread adaption kit provides you with reliability.

## ADDITIONAL TOOL DESIGNS

### INLINE DESIGN

The Inline Style Tool is designed for vertical installations. Contact AVK for information.



### RIGHT ANGLE DESIGN

The Right Angle Inline Style Tool is designed for limited access applications.



Contact AVK for information.

# AVK PNEUMATIC TOOLS PROFILE

The AVK pneumatic tool features a Quick-Change thread adaption kit. This patented\* feature allows for easy access to the thread size component parts. AVK's Pneumatic tools provide the highest RPM for the thread size selected resulting in optimum installation speed.

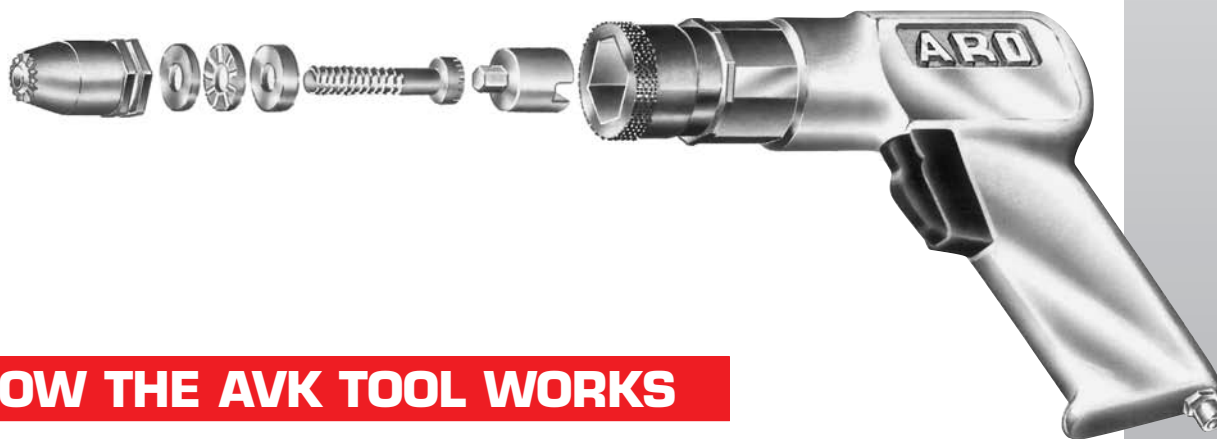

## HOW THE AVK TOOL WORKS

- ◆ The operator quarter turns an AVK threaded insert onto the tool mandrel and places it into the hole in the parent material.
- ◆ The top trigger is depressed and the tool mandrel spins into the insert.
- ◆ The head of the threaded insert is gripped by the knurling at the nose piece preventing it from spinning as the threaded area of the insert "walks" up the mandrel.
- ◆ As this occurs, the AVK insert expands within the hole wall providing hole fill and then forms a secondary flange against the backside of the parent material.
- ◆ The tool continues to torque the insert's threads causing the knurling to bite into the backside edge of the parent material.
- ◆ The tool then stalls when it reaches its predetermined stall torque. This occurs even if the parent material varies in thickness. The tool needs no adjustment to install AVK's products in variable thickness materials.
- ◆ The operator then presses the lower reverse trigger and the mandrel spins out of the installed part.

## ADDITIONAL TOOL DESIGNS

### HEAD FORMING THREAD ADAPTION KIT

A Head Forming T.A.K. is available to contour the AVK insert's head to the radius of a tube to increase torque capability.



Contact AVK for information.

### SPECIAL DESIGNS

AVK can design a thread adaption kit nose assembly to fit your particular application needs.



Contact AVK for information.



**PNEUMATIC TOOLS**

PREVIOUS PAGE

PRODUCT INDEX

NEXT PAGE

# AVK PNEUMATIC TOOL SPECIFICATIONS

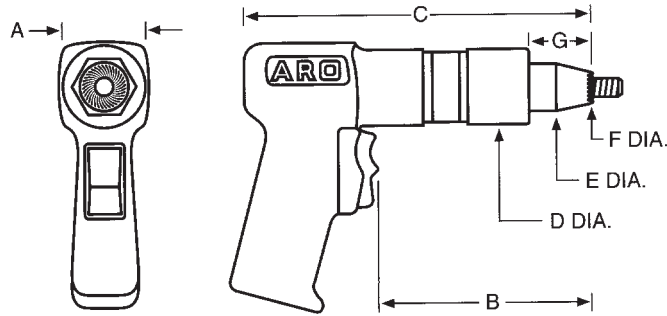

The tool shown on this page has been specifically designed to install the A-L, A-K, A-H, A-P and A-O Series Inserts.

Once you have selected the type of insert and thread size required for your application, select the appropriate RPM tool from the chart below.

## DIMENSIONAL DATA/TOOL SET-UP REQUIREMENTS

RPM	WEIGHT LBS.-Kg	A	B	C	D DIA.	E DIA.	F DIA. MAX.	G
3,000	2.55	1.86	4.75	7.75	1.57	1.00	.400	1.3
	1.15	47,24	120,6	196,8	39,87	25,4	10,16	33,0
1,500	2.58	1.86	4.75	7.75	1.57	1.00	.400	1.3
	1.17	47,24	120,6	196,8	39,87	25,4	10,16	33,0
900	3.18	1.86	6.00	9.00	1.57	1.00	.500	1.3
	1.44	47,24	152,4	228,6	39,87	25,4	12,7	33,0
600	3.18	1.86	6.00	9.00	1.57	1.00	.640	1.3
	1.44	47,24	152,4	228,6	39,87	25,4	16,25	33,0
350	3.25	1.86	5.37	8.37	1.50	1.42	.900	NA
	1.46	47,24	136,3	212,5	38,1	36,06	22,86	NA

### PROPER AIR SUPPLY SET-UP REQUIRES:

- ◆ 90-110 PSI (6.2-7.5 BARS) dynamic (tool running) air pressure at 25 S.C.F.M.
- ◆ Inline oiler/separator
- ◆ Air pressure gauge and regulator
- ◆ 5/16 or 7,92 mm minimum hose ID
- ◆ 5/16 or 7,92 mm minimum fittings ID

**SPECIAL FEATURE**—The AKPT nose cone design incorporates a special pilot/serrated tip that is essential to proper insert installation. The “A-K” prefix in the tool part number designates this feature.

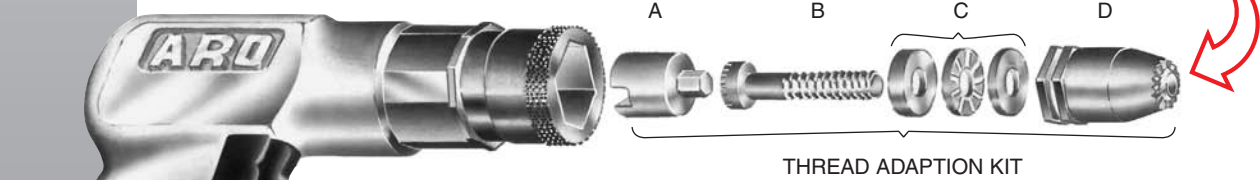

THREAD ADAPTION KIT

## AIR TOOL SELECTION/SPARE PARTS

THREAD SIZE	TOOL R.P.M.	COMPLETE TOOL PART NUMBER	THREAD ADAPTION KIT	A HEX DRIVE	B MANDREL 10 PER BAG	C BEARING SET	D NOSE CONE	DYNAMIC AIR PRESSURE SETTINGS PSI - BARS	
6-32 UNC	3000	AKPT30P632	AKPT632TAK	29NPT22	B3SH632-1500	32PT 1	77AKPT6	70-80	This chart designates the tool, spare parts and dynamic (tool running) air pressure requirements for our most popular steel product. Consult the AVK tool catalog or contact AVK for tool RPM and air pressure settings for aluminum, brass and monel product.
8-32 UNC	3000	AKPT30P832	AKPT832TAK	29NPT23	B3SH832-1500	32PT 2	77AKPT8	75-90	
10-24 UNC	1500	AKPT15P1024	AKPT1024TAK	29NPT4	B3SH1024-1750	32PT 4	77AKPT10	60-80	
10-32 UNF	1500	AKPT15P1032	AKPT1032TAK	29NPT4	B3SH1032-1750	32PT 4	77AKPT10	60-80	
1/4-20 UNC	900	AKPT9P420	AKPT420TAK	29NPT5	B3SH420-1500	32PT 5	77AKPT250	70-90	
5/16-18 UNC	600	AKPT6P518	AKPT518TAK	29NPT6	B3SH518-2000	32PT 7	77AKPT3125	80-110	
3/8-16 UNC	600	AKPT6P616	AKPT616TAK	29NPT7	B3SH616-2000	32PT 8	77AKPT375	80-110	
1/2-13 UNC	350	AKPT3P813	AKPT813CTA	29NPT26	B3SH813-2500	30NPT500	77AKPT500	80-110	
M4 x 0,7 ISO	3000	AKPT30P470	AKPT470TAK	29NPT24	B3SH470-40	32PT 3	77AKPT470	4.8-5.5	
M5 x 0,8 ISO	1500	AKPT15P580	AKPT580TAK	29NPT10	B3SH580-45	32PT 4	77AKPT580	4.1-5.5	
M6 x 1,0 ISO	900	AKPT9P610	AKPT610TAK	29NPT11	B3SH610-40	32PT 6	77AKPT610	4.8-6.2	
M8 x 1,25 ISO	600	AKPT6P8125	AKPT8125TAK	29NPT12	B3SH8125-50	32PT 7	77AKPT8125	5.5-7.5	
M10 x 1,5 ISO	600	AKPT6P1015	AKPT1015TAK	29NPT25	B3SH1015-50	32PT 10	77AKPT1015	5.5-7.5	
M12 x 1,75 ISO	350	AKPT3P12175	AKPT12175CTA	29NPT27	B3SH12175-60	30NPT500	77AKPT12175	5.5-7.5	

NOTE: UNF FINE THREAD COMPONENTS ARE AVAILABLE.

### PREVENTATIVE MAINTENANCE REQUIREMENTS:

- ◆ The bearing set must be kept in a WET lubricated condition to assure proper tool operation. AVK suggests the use of high temperature grease such as LUBRIPLATE BRAND 930 AA.
- ◆ The tool mandrel should be inspected for thread wear or damage and replaced. To test the condition of the mandrel, thread an AVK insert onto the mandrel backwards until it touches the pilot. If any drag is still felt, replace the mandrel with Unbrako socket head cap screws.



# AVK PNEUMATIC TOOL SPECIFICATIONS

The tool shown on this page has been specifically designed to install the A-T and A-W Series Inserts.

Once you have selected the type of insert and thread size required for your application, select the appropriate RPM tool from the chart below.

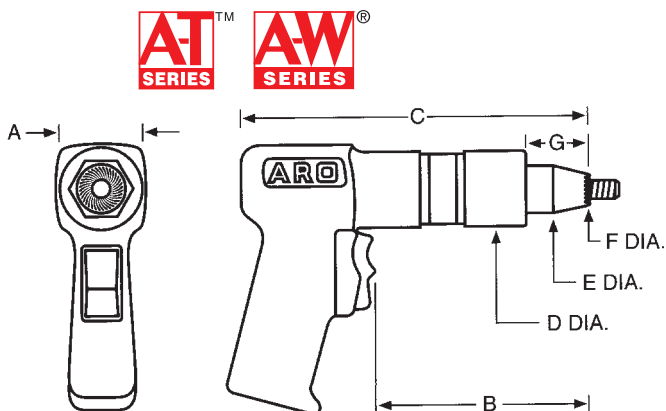

## DIMENSIONAL DATA/TOOL SET-UP REQUIREMENTS

PROPER AIR SUPPLY SET-UP REQUIRES:

- ◆ 90-110 PSI (6.2-7.5 BARS) dynamic (tool running) air pressure at 25 S.C.F.M.
- ◆ Inline oiler/separator
- ◆ Air pressure gauge and regulator
- ◆ 5/16 or 7,92 mm minimum hose ID
- ◆ 5/16 or 7,92 mm minimum fittings ID

RPM	WEIGHT LBS.-Kg	A	B	C	D DIA.	E DIA.	F DIA. MAX.	G
3,000	2.55	1.86	4.75	7.75	1.57	1.00	.350	1.3
	1.15	47,24	120,6	196,8	39,87	25,4	8,89	33.0
1,500	2.58	1.86	4.75	7.75	1.57	1.00	.600	1.3
	1.17	47,24	120,6	196,8	39,87	25,4	15,24	33.0
600	3.18	1.86	6.00	9.0	1.57	1.00	.625	1.3
	1.44	47,24	152,4	228,6	39,87	25,4	15,87	33.0
350	3.25	1.86	6.00	8.37	1.50	1.43	.900	NA
	1.46	47,24	152,4	212,5	38,1	36,32	22,86	NA

SPECIAL FEATURE—This NPT nose cone design incorporates a special serrated tip that is essential to proper insert installation. The “N” prefix in the tool part number designates this feature.

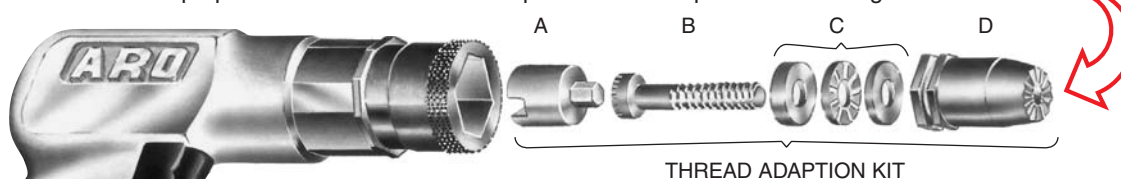

## AIR TOOL SELECTION/SPARE PARTS

THREAD SIZE	TOOL R.P.M.	COMPLETE TOOL PART NUMBER	THREAD ADAPTION KIT	A HEX DRIVE	B MANDREL 10 PER BAG	C BEARING SET	D NOSE CONE	DYNAMIC AIR PRESSURE SETTINGS PSI - BARS
4-40 UNC	3000	NPT30P440	NPT440TAK	29NPT1	B3SH440-750	30NPT 4	77NPT 4	36-40
6-32 UNC	3000	NPT30P632	NPT632TAK	29NPT2	B3SH632-875	30NPT 6	77NPT 6	70-80
8-32 UNC	3000	NPT30P832	NPT832TAK	29NPT3	B3SH832-875	30NPT 8	77NPT 8	60-85
10-24 UNC	1500	NPT15P1024	NPT1024TAK	29NPT4	B3SH1024-1500	30NPT 10	77NPT 10	60-85
10-32 UNF	1500	NPT15P1032	NPT1032TAK	29NPT4	B3SH1032-1500	30NPT 10	77NPT 10	60-85
1/4-20 UNC	1500	NPT15P420	NPT420TAK	29NPT5	B3SH420-1250	30NPT 250	77NPT 250	70-95
5/16-18 UNC	600	NPT6P518	NPT518TAK	29NPT6	B3SH518-1750	30NPT 3125	77NPT 3125	80-100
3/8-16 UNC	600	NPT6P616	NPT616TAK	29NPT7	B3SH616-1750	30NPT 375	77NPT 375	90-110
1/2-13 UNC	350	NPT3P813	NPT813CTA	29NPT26	B3SH813-2000	30NPT 500	77NPT 500	95-110
M3x0,5 ISO	3000	NPT30P350	NPT350TAK	29NPT8	B3SH350-20	30NPT M3	77NPTM3	2.4-2.7
M4x0,7 ISO	3000	NPT30P470	NPT470TAK	29NPT9	B3SH470-20	30NPT M4	77NPTM4	4.1-5.5
M5x0,8 ISO	1500	NPT15P580	NPT580TAK	29NPT10	B3SH580-40	30NPT M5	77NPTM5	4.1-5.5
M6x1,0 ISO	1500	NPT15P610	NPT610TAK	29NPT11	B3SH610-35	30NPT M6	77NPTM6	4.8-6.5
M8x1,25 ISO	600	NPT6P8125	NPT8125TAK	29NPT12	B3SH8125-45	30NPT M8	77NPTM8	5.5-6.8
M10x1,5 ISO	600	NPT6P1015	NPT1015TAK	29NPT25	B3SH1015-45	30NPT M10	77NPTM10	6.2-7.5
M12x1,75 ISO	350	NPT3P12175	NPT12175CTA	29NPT27	B3SH12175-50	30NPT 500	77NPTM12	6.2-7.5

This chart designates the tool, spare parts and dynamic (tool running) air pressure requirements for our most popular steel product. Consult the AVK tool catalog or contact AVK for tool RPM and air pressure settings for aluminum, brass and stainless product.

NOTE: UNF FINE THREADS COMPONENTS ARE AVAILABLE

PREVENTATIVE MAINTENANCE REQUIREMENTS:

- ◆ The bearing set must be kept in a WET lubricated condition to assure proper tool operation. AVK suggests the use of high temperature grease such as LUBRIPLATE BRAND 930 AA.
- ◆ The tool mandrel should be inspected for thread wear or damage and replaced. To test the condition of the mandrel, thread an AVK insert onto the mandrel backwards until it touches the knurled nose cone. If any drag is still felt, replace the mandrel with Unbrako socket head cap screws.

# AVK PNEUMATIC TOOL SPECIFICATIONS

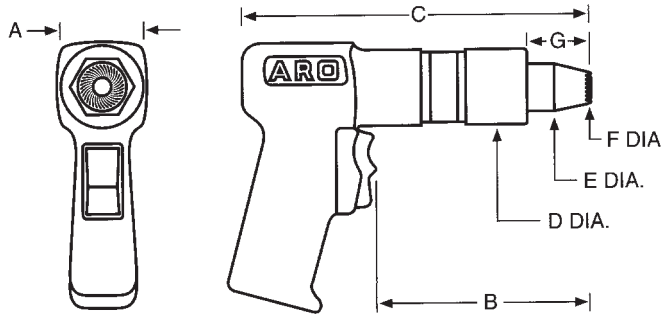

The tool shown on this page has been specifically designed to install the A-S Series Stud.

Once you have selected the type of stud and thread size required for your application refer to the chart below for air tool selection.

## DIMENSIONAL DATA/TOOL SET-UP REQUIREMENTS

RPM	WEIGHT LBS.-Kg	A	B	C	D DIA.	E DIA.	F DIA. MAX.	G
3,000	2.55	1.86	4.75	7.75	1.57	1.00	.400	1.3
	1.15	47,24	120,6	196,85	39,87	25,4	10,16	33,0
1,500	2.58	1.86	4.75	7.75	1.57	1.00	.400	1.3
	1.17	47,24	120,6	196,85	39,87	25,4	10,16	33,0
900	3.18	1.86	6.00	9.00	1.57	1.00	.500	1.3
	1.44	47,24	152,4	228,6	39,87	25,4	12,7	33,0
600	3.18	1.86	6.00	8.37	1.57	1.00	.640	1.3
	1.44	47,24	152,4	212,6	39,87	25,4	16,25	33,0

PROPER AIR SUPPLY SET-UP REQUIRES:

- ◆ 90-110 PSI (6.2-7.5 BARS) dynamic (tool running) air pressure at 25 S.C.F.M.
- ◆ Inline oiler/separator
- ◆ Air pressure gauge and regulator
- ◆ 5/16 or 7,92 mm minimum hose ID
- ◆ 5/16 or 7,92 mm minimum fittings ID

SPECIAL FEATURE—This tool nose cone design incorporates a special serration tip that is essential to proper insert installation.

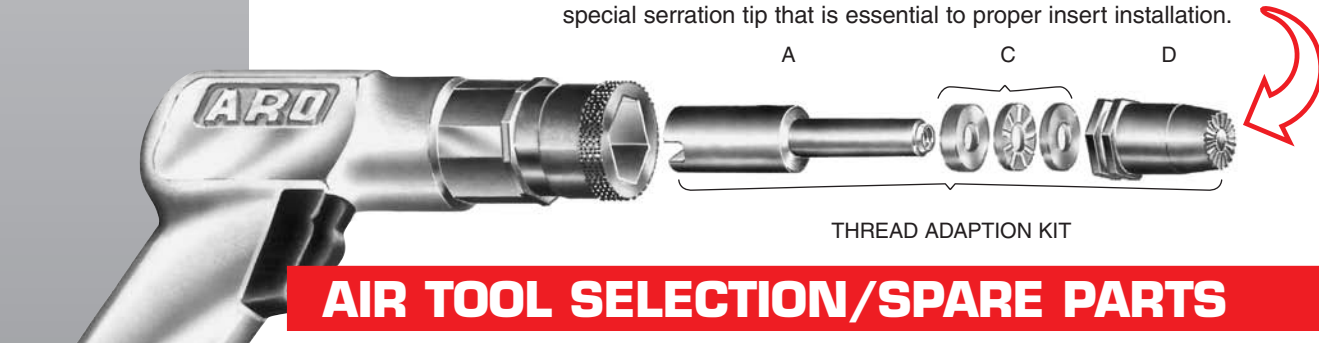

THREAD ADAPTION KIT

## AIR TOOL SELECTION/SPARE PARTS

THREAD SIZE	TOOL R.P.M.	COMPLETE TOOL PART NUMBER	THREAD ADAPTION KIT	A THREAD DRIVE	C BEARING SET	D NOSE CONE	DYNAMIC AIR PRESSURE SETTINGS PSI - BARS
6-32 UNC	3000	ASPT30P632	ASPT632TAK	29ASPT632	32PT5	77ASPT8	70-80
8-32 UNC	3000	ASPT30P832	ASPT832TAK	29ASPT832	32PT5	77ASPT8	75-90
10-24 UNC	1500	ASPT15P1024	ASPT1024TAK	29ASPT1024	32PT12	77ASPT10	60-80
10-32 UNF	1500	ASPT15P1032	ASPT1032TAK	29ASPT1032	32PT12	77ASPT10	60-80
1/4-20 UNC	900	ASPT9P420	ASPT420TAK	29ASPT420	32PT8	77ASPT4	70-90
5/16-18 UNC	600	ASPT6P518	ASPT518CTA	29ASPT518	30NPT500	77ASPT8125	80-110
3/8-16 UNC	600	ASPT6P616	ASPT616CTA	29ASPT616	30NPT500	77ASPT8125	80-110
M4 x 0,7 ISO	3000	ASPT30P470	ASPT470TAK	29ASPT470	32PT5	77ASPT8	4.8-5.5
M5 x 0,8 ISO	1500	ASPT15P580	ASPT580TAK	29ASPT580	32PT12	77ASPT10	4.1-5.5
M6 x 1,0 ISO	900	ASPT9P610	ASPT610TAK	29ASPT610	32PT8	77ASPT4	5.5-6.2
M8 x 1,25 ISO	600	ASPT6P8125	ASPT8125CTA	29ASPT8125	30NPT500	77ASPT8125	5.5-7.5
M10 x 1,5 ISO	600	ASPT6P1015	ASPT1015CTA	29ASPT1015	30NPT500	77ASPT8125	5.5-7.5

NOTE: Air pressure settings are specified dynamic (tool running).

PREVENTATIVE MAINTENANCE REQUIREMENTS:

- ◆ The bearing set must be kept in a WET lubricated condition to assure proper tool operation. AVK suggests the use of high temperature grease such as LUBRIPLATE BRAND 930 AA.



**PNEUMATIC TOOLS**

# AVK PNEUMATIC TOOL SPECIFICATIONS

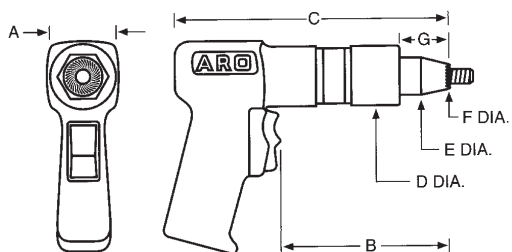

The tool shown on this page has been specifically designed to install the A-R Series Inserts.

AVK recommends that trial installations be performed to determine the optimum tool for the fastener selected using actual application materials and hole sizes. Tool RPM and parent material density will affect the grip range of the fastener. See the chart below for guidelines.

## DIMENSIONAL DATA/TOOL SET-UP REQUIREMENTS

PROPER AIR SUPPLY SET-UP REQUIRES:

- ◆ 90-110 PSI (6.2-7.5 BARS) dynamic (tool running) air pressure at 25 S.C.F.M.
- ◆ Inline oiler/separator
- ◆ Air pressure gauge and regulator
- ◆ 5/16 or 7,92 mm minimum hose ID
- ◆ 5/16 or 7,92 mm minimum fittings ID

RPM	WEIGHT LBS.-Kg	A	B	C	D DIA.	E DIA.	F DIA. MAX.	G
1,500	2.58	1.86	4.75	7.75	1.57	1.00	.400	1.3
	1.17	47,24	120,6	196,8	39,87	25,4	10,16	33,0
900	3.18	1.86	6.00	9.00	1.57	1.00	.500	1.3
	1.44	47,24	152,4	228,6	39,87	25,4	12,7	33,0

SPECIAL FEATURE—This NPT nose cone design incorporates a special serrated tip that is essential to proper insert installation. The “N” prefix in the tool part number designates this feature.

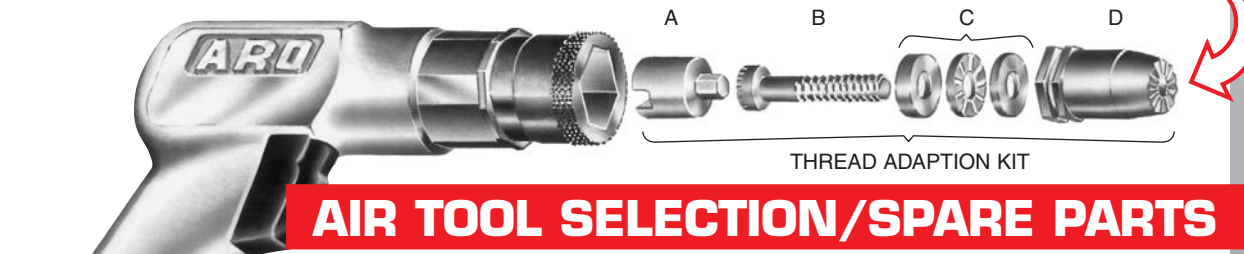

## AIR TOOL SELECTION/SPARE PARTS

AVK PART NUMBER	TOOL R.P.M.	PARENT MATERIAL	PARENT MATERIAL	COMPLETE TOOL PART NUMBER	THREAD ADAPTION KIT	A HEX DRIVE	B SCREW MANDREL	C BEARING SET	D NOSE CONE	DYNAMIC AIR PRESSURE SETTINGS PSI - BARS
		STEEL, ALUMINUM FIBERGLASS SML	BLOW, ROTATIONAL SOFT PLASTICS							
ARS4-420-280	1500	.020-.190	.020-.250	ARPT15P420-280	ARPT420-280TAK	29NP5	3SH420-2000	32PT5	77NPT250	60-70
	900	.020-.250	.020-.250	ARPT9P420-280						40-60
ARS4-420-500	1500	.250-.430	.250-.470	ARPT15P420-500	ARPT420-500TAK	29NPT5	3SH420-2250	32PT5	77NPT250	60-70
	900	.250-.470	.250-.470	ARPT9P420-500						40-60
ARS4-518-280	900	.020-.260	-	ARPT9P518-280	ARPT518-280TAK	29NPT6	3SH518-2500	32PT7	77NPT3125	70-90
	-	-	-	-						-
ARS4-518-500	900	*	-	ARPT9P-518-500	ARPT518-500TAK	29NPT6	3SH518-2750	32PT7	77NPT3125	70-90
	-	-	-	-						-
ARS4-616-280	600	.020-.260	-	ARPT6P-616-280	ARPT616-280TAK	29NPT7	3SH616-2500	32PT8	77NPT375	70-90
	-	-	-	-						-
ARS4-610-7.1	1500	0.5-4.8	0.5-6.3	ARPT15P610-7.1	ARPT610-7.1TAK	29NPT11	3SH610-50	32PT6	77NPTM6	4.1-4.8
	900	0.5-6.3	0.5-6.3	ARPT9P610-7.1						2.8-4.1
ARS4-610-12.7	1500	6.3-10.9	6.3-11.9	ARPT15P610-12.7	ARPT610-12.7TAK	29NPT11	3SH610-55	32PT6	77NPTM6	4.1-4.8
	900	6.3-11.9	6.3-11.9	ARPT9P610-12.7						2.8-4.1
ARS4-8125-7.1	900	0.5-6.6	-	ARPT9P8125-7.1	ARPT8125-7.1TAK	29NPT12	3SH8125-60	32PT7	77NPTM8	4.8-6.2
	-	-	-	-						-
ARS4-8125-12.7	900	*	-	ARPT9P8125-12.7	ARPT8125-12.7TAK	29NPT12	3SH8125-65	32P7	77NPTM8	4.8-6.2
	-	-	-	-						-
ARS4-1015-7.1	600	0.5-6.6	-	ARPT6P1015-7.1	ARPT1015-7.1TAK	29NPT25	3SH1015-60	32PT10	77NPT1015	4.8-6.2
	-	-	-	-						-

This chart designates the tool, spare parts and dynamic (tool running) air pressure requirements for our most popular steel product.

NOTE: UNF FINE THREAD COMPONENTS ARE AVAILABLE.

PREVENTATIVE MAINTENANCE REQUIREMENTS:

- ◆ The bearing set must be kept in a WET lubricated condition to assure proper tool operation. AVK suggests the use of high temperature grease such as LUBRIPLATE BRAND 930 AA.
- ◆ The tool mandrel should be inspected for thread wear or damage and replaced. To test the condition of the mandrel, thread an AVK insert onto the mandrel backwards until it touches the pilot. If any drag is still felt, replace the mandrel with Unbrako socket head cap screws.

## NEW SPP2™ TOOL SYSTEM INTRODUCTION

The New SPP2™ Modularized Tool System has been designed exclusively to install AVK's complete line of blind installed fastener. The term SPP2™ stands for Spin Pull to Pressure. The SPP2™ tool spins into the AVK fastener, automatically pulling the fasteners into a proper installation utilizing pressure as the upset control method. Pulling to pressure insures the AVK fastener will be installed correctly into single, multiple or variable thickness materials without adjustment.

## THE TOOL SYSTEM FEATURES

- ◆ The Power Pack contains the air over hydraulic power system. The Power Pack is capable of providing 7,500 pounds of pulling force enabling the tool to install any AVK product in any thread size up to 1/2" and M12. Combined with a NEW Pneumatic-Hydraulic Boost System providing a 15% to 20% faster cycle time for rapid installation.
- ◆ The all new SPP2™ comes furnished with attached tool hangers, casters and durable air and hydraulic quick release fittings allowing the operator to pull the unit along the work floor.
- ◆ The Power Pack can be adjusted to pull any AVK fastener with the simple adjustment of an air pressure regulator. Our new robust design features a see through glass hydraulic fluid reservoir for visual inspection of the hydraulic fluid level, enabling quick and easy adjustments.
- ◆ The SPP2™ tool is lightweight and ergonomically designed. It features a rocker style trigger and a high speed motor that provides the quickest spin-in / spin-out of any tool on the market. The tool also has a patented quick release thread adaptation kit that makes thread size changes quick and easy with no wrenches required.

## THE INSTALLATION SEQUENCE IS AS FOLLOWS

- ◆ 1/4 turn the AVK fastener onto the tool mandrel and insert it into the hole.
- ◆ Squeeze the top trigger and the mandrel spins into the threads of the AVK part. Once fully threaded the tool's air motor stalls and triggers the power pack to provide the pull force setting the AVK product.
- ◆ Squeeze the lower trigger and the air motor reverses, spinning the mandrel out of the installed AVK product.

**BEFORE USING THE SPP2™ TOOL SYSTEM PLEASE READ THIS ENTIRE MANUAL TO AVOID DAMAGE TO THE TOOL OR POSSIBLE BODILY INJURY.**



# TOOL SPECIFICATIONS

**PISTOL STYLE TOOL**

APPROXIMATE WEIGHT (WITH TAK): 3.71 LBS (1.68 kg)

**IN-LINE STYLE POWER TOOL**

APPROXIMATE WEIGHT (WITH TAK): 4.29 LBS (1.95 kg)

**MINI PISTOL STYLE TOOL**

APPROXIMATE WEIGHT: 2.95 LBS (1.34 kg)  
2600 RPM AIR MOTOR  
PULLING STROKE: 0.250\"/>

The SPP2 hose assembly is available in 6', 8', 10', and 15' lengths. Hose weight 6'= 1.1 lbs., 8'= 1.32 lbs., 10'= 1.51 lbs., 15'= 2.0 lbs.

# POWER CONTROL SYSTEM DIMENSIONS

HANGER DIAMETER: 0.500\" (12.7 MM.) MIN. 0.700\" (17.8 MM.) MAX.

The hydraulic pull force capability of the SPP2 tool is 7,500 lbs. max (35.6 kN) at 80 psi. Air pressure requirement to the power control system is 90 psi dynamic (6.2 bars).

# PRODUCT/TOOL SELECTION

Product tool section added note: SPP2 Tools per the part numbers below will be supplied with mandrels to install 1<sup>st</sup> and 2<sup>nd</sup> grip fasteners. If longer grip fasteners are being used contact AVK for appropriate mandrel part numbers.

PRODUCT SERIES	THREAD SIZE	STEEL	BRASS	ALUMINUM	MONEL	STAINLESS STEEL
A-K, A-L	#6—1/2 M4-M12	✓	✓	✓	✓	N/A
A-H	#6—1/2 M4-M12	✓	✓	✓	✓	✓
A-S	#6—3/8 M4-M10	✓	N/A	N/A	N/A	N/A
A-R	1/4—3/8 M6-M10	✓	N/A	N/A	N/A	N/A
A-T	#4—1/2 M3-M12	✓	✓	✓	✓	✓
A-W	#6—3/8 M4-M10	✓	✓	N/A	N/A	N/A
A-O	#6—3/8 M4-M10	✓	N/A	N/A	✓	N/A
R-N	#4—1/2 M3-M12	✓	N/A	✓	N/A	✓ (up to 3/8 & M10)

System Type	TOOL TYPE		HOSE LENGTH	CALL OUT	POWER CONTROL TYPE	CALL OUT	SERIES	AVK THREAD SIZE CALL OUT  SAMPLE NUMBER: SPP2P8AL420
	PISTOL	P	6'	6	NO CALL OUT	AL	A-L, A-K, A-H, A-O	
	IN LINE	IL	8'	8		AR	A-R	
	MINI PISTOL	MP	10'	10		RN	R-N, A-T, A-W	
		15'	15	AS		A-S		

NOTE: See SPP2™ tool manual for set up, spare parts and preventative maintenance.

## AVK AUTOMATED INSTALLATION EQUIPMENT

AVK, in collaboration with Alliance Automation, has recognized the ever-increasing market demand for semi and fully automated custom insert installation equipment. The Dyna-System™ automated insert placing system is designed to meet high volume insert production assembly requirements maximizing facility output and reducing labor-intensive activities. Team AVK/Alliance can provide automated insert work stations and robotic arms utilizing micro-processors, electro-pneumatic circuitry, self diagnostic systems, light bar activated switches, light curtains and just about whatever your specification(s) may call for. For further information and to arrange a joint sales call and quotation inquiry, please contact your AVK Sales Representative today!



### **DYNA-SET™ AUTOMATED BLIND THREADED INSERT ASSEMBLY**

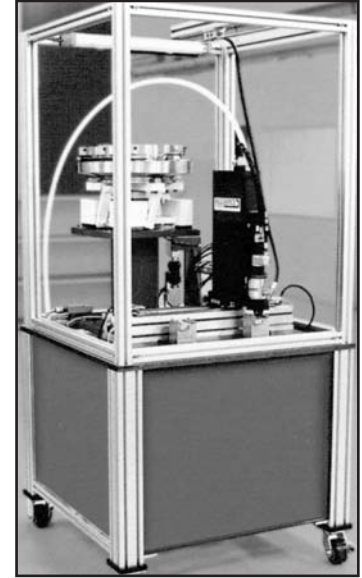

## OVERVIEW

Since 1983 AVK Industrial Products have been the vanguard of blind threaded structural insert and blind threaded stud technology. AVK is the design originator of "Spinwall Technology™" maximizing grip-range, blind side upset and ease of installation capability. AVK offers 12 high performance insert and stud product lines, as well as, customization of standard insert and stud products for your assembly system solution. The AVK/Alliance Team is expanding our fastening system abilities by offering semi and fully automated options for a multitude of sheet metal, composite, extrusion and hydro-formed structure assemblies; replacing among other things labor intensive weld nuts, sheet metal rivets, and self tapping screws. The Alliance Dyna-Set™ System combined with AVK inserts provides the ultimate high-speed labor saving assembly solution.

### **Dyna-Set™ Technology**

The patent-pending design of the Dyna-Set™ automated insert system and Material Handling Module utilizes spin pull tool technology. The Dyna-Set™ will replace antiquated canister pneumatic hydraulic spin pull to stroke tools and provide greater reliability and maximize assembly capability. Some of the Dyna-Set™ benefits are as follows:

- ◆ Labor savings
- ◆ Single or multi-simultaneous insert installation
- ◆ Maximum up-time providing optimal production output
- ◆ Multiple work station configurations are available
- ◆ Robotic arm with hole locating vision system is available
- ◆ Insert collapse load can be verified
- ◆ Dyna-Set™ systems are self diagnostic

In addition to the above benefits, Dyna-Set's™ unique quick change chuck features the capability of replacing a mandrel without the use of tools. The Dyna-Set™ system can be mounted in any orientation, 360°, installing inserts from above, below or the side of a work piece. Its slim profile allows the Dyna-Set™ automated insert system and Material Handling Module to be mounted on three-inch centers, x,y,z slide configuration or a robotic arm providing maximum installation flexibility and labor reduction. The Dyna-Set™ System will handle AVK's A-L Series™ inserts, A-K Series™ inserts, A-H Series™ inserts, A-S Series™ and other customized components. AVK inserts are available in unified and Metric threads ranging in size from #440 through 5/16 unified and M3 through M8.



**PNEUMATIC  
HYDRAULIC  
TOOLS**

# AVK PNEUMATIC-HYDRAULIC TOOL SPECIFICATIONS

The tool shown on this page has been specifically designed to install the R-N Series Rivet Nuts.



Once you have selected the type of insert and thread size required for your application refer to the chart below for air tool selection.

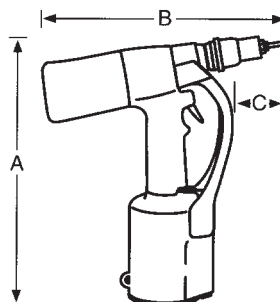

RNPT 751

## DIMENSIONAL DATA/TOOL SET-UP REQUIREMENTS

PROPER AIR SUPPLY SET-UP REQUIRES:

- ◆ 85-100 PSI (5.8-6.8 BARS) dynamic air pressure at 17 S.C.F.M.
- ◆ Inline oiler/separator
- ◆ Air pressure gauge and regulator
- ◆ 5/16 or 7,92 mm minimum hose ID
- ◆ 5/16 or 7,92 mm minimum fittings ID

TOOL PART NUMBER	WEIGHT LBS.-kN.	PULL POWER LBS.-kN.	A	B	C
RNPT 751	6 LBS. 2.7 kN.	3,500 LBS. 15.6 kN.	11.50 292,1	11.00 279,4	2.00 50,8

TOOL SET-UP

The RNPT 751 tool installs the rivet nuts by applying a controlled length stroke. The length of stroke is determined by the fastener size and parent material thickness. Please contact AVK for stroke specifications.



RNPT 751 THREAD ADAPTION KIT

## AIR TOOL SELECTION/SPARE PARTS

RNPT 751		
THREAD SIZE	THREAD ADAPTION KIT	A MANDREL
6-32 UNC	RNPT750-632TAK	18RNPT750-632
8-32 UNC	RNPT750-832TAK	18RNPT750-832
10-24 UNC	RNPT750-1024TAK	18RNPT750-1024
10-32 UNF	RNPT750-1032TAK	18RNPT750-1032
1/4-20 UNC	RNPT750-420TAK	18RNPT750-420
5/16-18 UNC	RNPT750-518TAK	18RNPT750-518
3/8-16 UNC	RNPT750-616TAK	18RNPT750-616
M4x0,7 ISO	RNPT750-470TAK	18RNPT750-470
M5x0,8 ISO	RNPT750-580TAK	18RNPT750-580
M6x1,0 ISO	RNPT750-610TAK	18RNPT750-610
M8x1,25 ISO	RNPT750-8125TAK	18RNPT750-8125
M10x1,50 ISO	RNPT750-1015TAK	18RNPT750-1015

The RNPT 751 is used to install Rivet-Nuts of the following materials.  
 Steel: 6-32 thru 5/16-18 and M4 thru M8  
 Aluminum: 6-32 thru 3/8-16 and M4 thru M10  
 Stainless Steel: SEE NOTE BELOW

**NOTE:** The RNPT751 is not recommended for installing stainless steel R-N Series. Please contact AVK for assistance.

## AVK HAND TOOL SPECIFICATIONS

The tools shown on this page are engineered to install AVK's...



### EXPENDABLE TOOLS

The following expendable tools are ideal for field repairs or consumer installation of AVK's products. Thread the AVK fastener onto the tool mandrel all the way up. Hold the tool with a box wrench and turn the mandrel with another box wrench or ratchet wrench until the AVK fastener is installed.

#### A-K, A-L, A-P, AND A-O SERIES

##### 1st AND 2nd GRIP PRODUCT

##### MODEL AA184

THREAD SIZE	TOOL PART NO.
4-40 UNC	N/A
6-32 UNC	AA184-632
8-32 UNC	AA184-832
10-24 UNC	AA184-1024
10-32 UNF	AA184-1032
1/4-20 UNC	AA184-420
5/16-18 UNC	AA184-518
3/8-16 UNC	AA184-616
1/2-13 UNC	AA184-813
M3 x 0,5 ISO	N/A
M4 x 0,7 ISO	AA184-470
M5 x 0,8 ISO	AA184-580
M6 x 1,0 ISO	AA184-610
M8 x 1,25 ISO	AA184-8125
M10 x 1,5 ISO	AA184-1015
M12 x 1,75 ISO	AA184-12175

#### A-T AND A-W SERIES

##### STANDARD PRODUCT

##### MODEL AAT916

THREAD SIZE	TOOL PART NO.
4-40 UNC	AAT916-440
6-32 UNC	AAT916-632
8-32 UNC	AAT916-832
10-24 UNC	AAT916-1024
10-32 UNF	AAT916-1032
1/4-20 UNC	AAT916-420
5/16-18 UNC	AAT916-518
3/8-16 UNC	AAT916-616
1/2-13 UNC	AAT916-813
M3 x 0,5 ISO	AAT916-350
M4 x 0,7 ISO	AAT916-470
M5 x 0,8 ISO	AAT916-580
M6 x 1,0 ISO	AAT916-610
M8 x 1,25 ISO	AAT916-8125
M10 x 1,5 ISO	AAT916-1015
M12 x 1,75 ISO	AAT916-12175

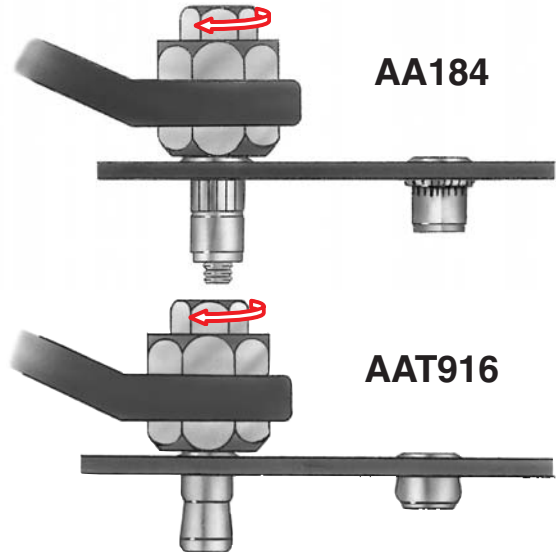

### AA170 PLIER TOOL

The AA170 tool is ideal for prototyping or making repairs with the A-K, A-L, A-H, A-P and A-O Series threaded inserts.

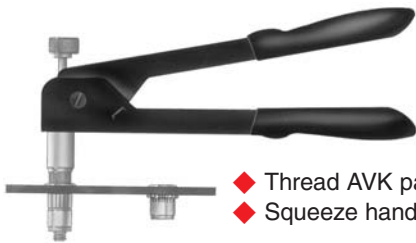

- ◆ Thread AVK part onto tool
- ◆ Squeeze handles

THREAD SIZE	CONVERSION KIT
6-32 UNC	AA271-632
8-32 UNC	AA271-832
10-24 UNC	AA271-1024
10-32 UNF	AA271-1032
1/4-20 UNC	AA271-420
5/16-18 UNC	AA271-518*
3/8-16 UNC	AA271-616*
M4 x 0,7 ISO	AA271-470
M5 x 0,8 ISO	AA271-580
M6 x 1,0 ISO	AA271-610
M8 x 1,25 ISO	AA271-8125*
M10 x 1,5 ISO	AA271-1015*

\*These sizes cannot be used with 2nd grip AVK fasteners.

### AA112 HI-TORQUER®

The AA112 is ideal for prototyping or making repairs with the A-T and A-W Series threaded inserts. It features a patented Quick Change thread size nose assembly.



#### INSTALLATION:

- ◆ Thread insert fully onto mandrel.
- ◆ Place into hole.
- ◆ Hold grip bar while turning the "T" handle clockwise until insert is installed.
- ◆ Turn "T" handle counter clockwise to remove from insert.

THREAD SIZE	CONVERSION KIT
4-40 UNC	AAT202-440
6-32 UNC	AAT202-632
8-32 UNC	AAT202-832
10-24 UNC	AAT202-1024
10-32 UNF	AAT202-1032
1/4-20 UNC	AAT202-420
5/16-18 UNC	AAT202-518
3/8-16 UNC	AAT202-616
M3 x 0,5 ISO	AAT202-350
M4 x 0,7 ISO	AAT202-470
M5 x 0,8 ISO	AAT202-580
M6 x 1,0 ISO	AAT202-610
M8 x 1,25 ISO	AAT202-8125
M10 x 1,5 ISO	AAT202-1015



**HAND TOOLS**

# AVK HAND TOOL SPECIFICATIONS

The hand tools shown on this page are used to install the A-L, A-K, A-H, A-P, A-O, R-N and A-S Series Products.



## AA480 DOUBLE ACTION LEVER TOOL

The AA480 tool features a visual stroke indicator and a convenient spin-off removal knob. This tool installs the full range of AVK's spinwall technology product in steel and aluminum and limited sizes of steel and aluminum rivet nuts. See chart below.



### INSTALLATION:

- ◆ Set the appropriate stroke per the AVK tool instruction sheet.
- ◆ Thread product fully onto tool mandrel.
- ◆ Place into the hole in your parent material.
- ◆ Squeeze tool handles together until product is fully collapsed.
- ◆ Spin center knob counter-clockwise unthreading tool mandrel from installed product.

## AA510 PLUNGER-DOUBLE ACTION LEVER TOOL

The AA510 tool features a visual stroke indicator and a quick acting pull to remove plunger. Due to its larger size, this tool installs the full range of AVK's Spinwall Technology™ Threaded Insert Product in all materials and various steel and aluminum rivet nuts. See chart below.

### INSTALLATION:

- ◆ Set the appropriate stroke per the AVK tool instruction sheet.
- ◆ Withdraw plunger from tool.
- ◆ Hold product over tool mandrel while pushing plunger into tool fully threading product onto the tool mandrel.
- ◆ Place into hole in your parent material.
- ◆ Squeeze tool handles together until product is fully collapsed.
- ◆ Pull plunger from tool unthreading mandrel from installed product.

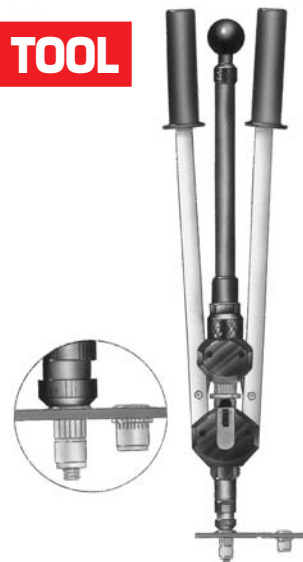

The chart below indicates the capability of the AA480 and AA510 to install a wide variety of AVK steel and aluminum products. Once you've selected the AVK product and thread size, refer to the chart and select the appropriate tool and conversion kit. • Denotes the product can be installed with the AA480 tool. + Denotes the product can be installed with the AA510 tool.

THREAD SIZE	INSERT MATERIAL		A-L, A-K, A-H, A-P, A-O SERIES INSERTS		INSERT MATERIAL		R-N SERIES RIVET NUTS		STUD MATERIAL		A-S SERIES STUDS	
	STEEL	ALUM	CONVERSION KIT #	REPLACEMENT MANDREL #	STEEL	ALUM	CONVERSION KIT #	REPLACEMENT MANDREL #	STEEL	CONVERSION KIT #	REPLACEMENT MANDREL #	
4-40 UNC			NA	NA	• +	• +	AA483-440	18AA481-440		NA	NA	
6-32 UNC	• +	• +	AA481-632	18AA481-632	• +	• +	AA483-632	18AA481-632	•	AA485-632	18AA485-632	
8-32 UNC	• +	• +	AA481-832	18AA481-832	• +	• +	AA483-832	18AA481-832	•	AA485-832	18AA485-832	
10-24 UNC	• +	• +	AA481-1024	18AA481-1024	• +	• +	AA483-1024	18AA481-1024	•	AA485-1024	18AA485-1024	
10-32 UNF	• +	• +	AA481-1032	18AA481-1032	• +	• +	AA483-1032	18AA481-1032	•	AA485-1032	18AA485-1032	
1/4-20 UNC	• +	• +	AA481-420	18AA481-420	•	• +	AA483-420	18AA481-420	•	AA485-420	18AA485-420	
5/16-18 UNC	• +	• +	AA481-518	18AA481-518	•	• +	AA483-518	18AA481-518	•	AA485-518	18AA485-518	
3/8-16 UNC	• +	• +	AA481-616	18AA481-616		• +	AA483-616	18AA481-616	•	AA485-616	18AA485-616	
1/2-13 UNC		• +	AA481-813	18AA481-813			NA	NA		NA	NA	
M3 x 0,5 ISO			NA	NA	• +	• +	AA483-350	18AA481-350		NA	NA	
M4 x 0,7 ISO	• +	• +	AA481-470	18AA481-470	• +	• +	AA483-470	18AA481-470	•	AA485-470	18AA485-470	
M5 x 0,8 ISO	• +	• +	AA481-580	18AA481-580	• +	• +	AA483-580	18AA481-580	•	AA485-580	18AA485-580	
M6 x 1,0 ISO	• +	• +	AA481-610	18AA481-610	•	• +	AA483-610	18AA481-610	•	AA485-610	18AA485-610	
M8 x 1,25 ISO	• +	• +	AA481-8125	18AA481-8125	•	• +	AA483-8125	18AA481-8125	•	AA485-8125	18AA485-8125	
M10 x 1,5 ISO	• +	• +	AA481-1015	18AA481-1015		• +	AA483-1015	18AA481-1015	•	AA485-1015	18AA485-1015	
M12 x 1,75 ISO		• +	AA481-12175	18AA481-12175			NA	NA		NA	NA	

**NOTE:** Additional UNF fine thread sizes are available. Contact AVK for details.

**WARNING:** Failure to adjust the appropriate stroke setting per the AVK tool instruction sheet may damage the tool.

# AVK KIT SPECIFICATIONS

The Master Assortment Kits shown on this page have been designed for prototype, maintenance and repair applications.

## A-L SERIES INSERT MASTER ASSORTMENT KITS

The A-L Series Kit is ideal for prototype and maintenance repair applications. The rugged hard shell plastic kit contains quantities of the A-L Series threaded inserts and the AA170 plier tool shown on page 38. It also contains a full compliment of thread size conversion kits and instruction label.



INCH SIZE KIT PART NUMBER AVK 2292			
THREAD SIZE	INSERT QUANTITY	REFILL PAK PART NUMBER	CONVERSION KIT PART NUMBER
6-32 UNC	50	AALS4-632-80	AA271-632
8-32 UNC	50	AALS4-832-80	AA271-832
10-32 UNF	50	AALS4-1032-130	AA271-1032
1/4-20 UNC	50	AALS4-420-165	AA271-420
5/16-18 UNC	25	AALS4-518-150	AA271-518
3/8-16 UNC	25	AALS4-616-150	AA271-616

METRIC SIZE KIT PART NUMBER AVK 2293			
THREAD SIZE	INSERT QUANTITY	REFILL PAK PART NUMBER	CONVERSION KIT PART NUMBER
M4 x 0,7 ISO	50	AALS4-470-2.0	AA271-470
M5 x 0,8 ISO	50	AALS4-580-3.3	AA271-580
M6 x 1,0 ISO	50	AALS4-610-4.2	AA271-610
M8 x 1,25 ISO	25	AALS4-8125-3.8	AA271-8125
M10 x 1,5 ISO	25	AALS4-1015-3.8	AA271-1015

## A-T SERIES INSERT MASTER ASSORTMENT KITS

The A-T Series master assortment kit is ideal for prototype and maintenance repair applications. The rugged hard shell plastic kit contains quantities of the A-T Series Inserts and the AA 112 Hi-torquer tool shown on page 38. It also contains a full compliment of thread size conversion kits and instruction label.



INCH SIZE KIT PART NUMBER AAT312A			
THREAD SIZE	INSERT QUANTITY	REFILL PAK PART NUMBER	CONVERSION KIT PART NUMBER
4-40 UNC	50	AAT400-440	AAT202-440
6-32 UNC	50	AAT400-632	AAT202-632
8-32 UNC	50	AAT400-832	AAT202-832
10-32 UNF	50	AAT400-1032	AAT202-1032
1/4-20 UNC	50	AAT400-420	AAT202-420
5/16-18 UNC	25	AAT400-518	AAT202-518

METRIC SIZE KIT PART NUMBER AAT312B			
THREAD SIZE	INSERT QUANTITY	REFILL PAK PART NUMBER	CONVERSION KIT PART NUMBER
M3 x 0,5 ISO	50	AAT400-350	AAT202-350
M4 x 0,7 ISO	50	AAT400-470	AAT202-470
M5 x 0,8 ISO	50	AAT400-580	AAT202-580
M6 x 1,0 ISO	50	AAT400-610	AAT202-610
M8 x 1,25 ISO	25	AAT400-8125	AAT202-8125

## DESIGN CONSIDERATIONS/APPLICATION CHECKLIST

The following BEST PRACTICE information should be considered to insure proper application design when using AVK fasteners. If you have any application questions, please contact AVK.

### PARENT MATERIAL

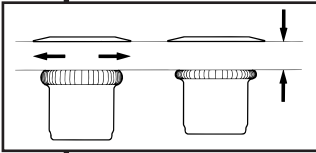

The parent material should be dense enough to support the hole fill and clamp load applied by the AVK fastener during installation. Its thickness should be within the grip range of the AVK fastener. Experimentation is suggested to determine optimum fastener selection for plastics.

### HOLE SIZE

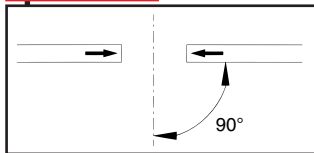

The hole produced in the parent material should be per the AVK catalog specifications. Tolerance for paint or coating buildup should be included to avoid an undersized hole condition. The hole should be square to the parent material.

### AVK PART ACCESS

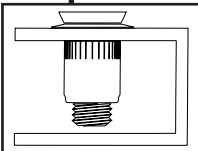

The AVK fastener head should sit flat on the parent material. An obstruction to the tail of the AVK product or to the access of the power tool can be corrected by contacting AVK for alternative fastener designs and tooling configurations. The AVK tool should be held perpendicular to the application to avoid excess mandrel wear.

### BACKSIDE SURFACE

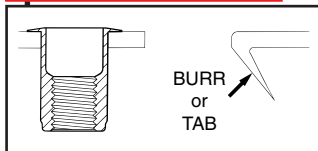

The backside surface of the parent material should not contain a punch slug or excessive burr that exceeds the grip range of the AVK fastener. Such large obstructions may prohibit the AVK fastener from installing properly.

### AIR SUPPLY

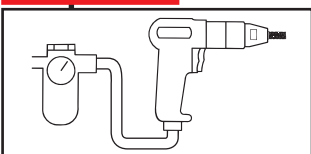

AVK's Spinwall Technology™ ARO brand installation tools require a pressure range of 60-110 PSI (4,1-7,5 BARS) at 25 S.C.F.M. of volume. Hose and fitting inside diameters need to be a minimum of 5/16 (7,92). An inline oiler and pressure regulator is required. Pressure should be measured as dynamic with the tool running.

### MATING PART HOLE SIZE/ALIGNMENT

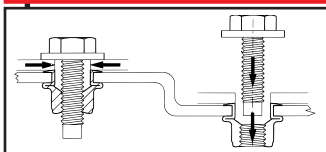

The mating part being attached should be non-rotational and contact the head of the AVK fastener. Its hole size should be .040 (1,0) smaller than the head diameter of the AVK fastener. The alignment of the mating part must provide perpendicular entry of the mating fastener into the AVK fastener.

### MATING FASTENER

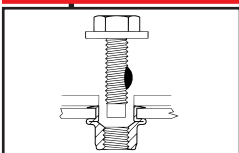

For the A-K, A-L, A-T, A-W and A-O Series™ the mating fastener should be of a "free-spinning" design and of the grade or class as indicated in this catalog. If a mechanical, chemical locking or prevailing torque element is required, AVK recommends the design selection of the A-H Series™ in a hex punched hole. Specification of a dog point screw will minimize cross threading and speed the assembly process in any AVK application. Mating screws should be hand started and then power driven to minimize cross threading.

### ASSEMBLY TORQUE

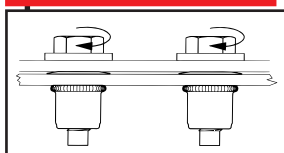

For appropriate assembly torques, see the suggested assembly torque data contained on page 42. AVK's products, when used per the data provided in this catalog, have been designed to be compatible with the torque requirements of Grade 5 or Metric Class 8.8/9.8 screws. AVK suggests customer testing to determine the optimum torque due to mating component fit and mating fastener lubrication/finish variations.

# AVK TEST DATA

The test data on this page is intended to provide the designer with approximate strength values in various materials and thicknesses. The figures shown are averages of multiple tests. AVK recommends that this data be used only as a guide since various application factors may affect AVK product performance. We recommend testing your application when an exact strength figure is required or the load to be applied comes close to the published data.

Unified (Inch) thread size data is provided in pounds (lbs.) for force and inch pounds (in-lbs.) for torque. Metric data is provided in kilonewtons (kN) for force and newton meters (Nm) for torque.



**PULL-OUT** is the force required to pull the AVK product from the parent material. The parent material is restrained by a hold down ring 3x the AVK part "D" dim.

**PUSH-OUT** is the force required to push the AVK product through the parent material. The parent material is supported by a hold down ring 3x the AVK part "D" dim.

**SPIN-OUT** is the torque required to turn the AVK product in the parent material after installation without influencing clamp load on the AVK product.

**ASSEMBLY TORQUE** is the amount of torque suggested for Grade 5 or Metric Class 8.8/9.8 mating hardware based on industry standards.

A-L, A-K, A-H, A-S™ product was tested with the -4 finish. R-N Series® was Cadmium plated.

	THREAD SIZE	PULL-OUT								PUSH-OUT	SPIN-OUT*		ASSEMBLY TORQUE
		IN STEEL SHEET				IN ALUMINUM SHEET				IN STEEL	IN STEEL	IN ALUM	
		.030"	.062"	.090"	.125"	.030"	.062"	.090"	.125"	.125"	.062"	.062"	
A-L / A-K SERIES	6-32	310	850	1570	1830	320	830	1450	1580				12
	8-32	310	850	1570	1830	320	830	1450	1580				22
	10-24	460	1020	1730	2670	440	1000	1700	2380				32
	10-32	460	1020	1730	2670	440	1000	1700	2380				36
	1/4-20	510	1270	2090	3250	490	1180	1920	3020				75
	5/16-18	520	1370	2380	3810	500	1350	2230	3670				156
	3/8-16	520	1370	2380	3810	500	1350	2230	3670				276
	1/2-13		2000	3040	4480		1830	2940	4350				660
	M4	1.4	3.8	7.0	8.1	1.4	3.7	6.5	7.0				2.5
	M5	2.0	4.5	7.7	11.9	2.0	4.5	7.6	10.6				5.0
	M6	2.3	5.7	9.3	14.5	2.2	5.3	8.5	13.4				8.6
	M8	2.3	6.1	10.6	17.0	2.2	6.0	9.9	16.3				21.0
M10	2.3	6.1	10.6	17.0	2.2	6.0	9.9	16.3				42.0	
M12		8.9	13.5	19.9		8.1	13.1	19.4				72.0	
A-H SERIES	6-32	270	660	990	860	270	660	830	840		40	40	12
	8-32	270	660	990	860	270	660	830	840		40	40	22
	10-24	420	990	1670	2520	380	880	1550	2050		80	70	32
	10-32	420	990	1670	2520	380	880	1550	2050		80	70	36
	1/4-20	460	1150	1780	2690	430	1530	2240	3210		130	90	75
	5/16-18	480	1110	1870	2280	460	1050	1680	2890		240	230	156
	3/8-16	480	1110	1870	2280	460	1050	1680	2890		240	230	276
	M4	1.2	2.9	4.4	3.8	1.2	2.9	3.7	3.7		4.5	4.5	2.5
	M5	1.9	4.4	7.4	11.2	1.7	3.9	6.9	9.1		9.0	7.9	5.0
	M6	2.0	5.1	7.9	12.0	1.9	6.8	10.0	14.3		14.7	10.2	8.6
	M8	2.1	4.9	8.3	10.1	2.0	4.7	7.5	12.9		27.1	25.5	21
	M10	2.1	4.9	8.3	10.1	2.0	4.7	7.5	12.9		27.1	25.5	42
A-S SERIES	6-32	310	850	1570	1830	320	830	1450	1580	630			12
	8-32	310	850	1570	1830	320	830	1450	1580	630			22
	10-24	460	1020	1730	2670	440	1000	1700	2380	580			32
	10-32	460	1020	1730	2670	440	1000	1700	2380	580			36
	1/4-20	510	1270	2090	3250	490	1180	1920	3020	880			75
	5/16-18	520	1370	2380	3810	500	1350	2230	3670	1140			156
	3/8-16	520	1370	2380	3810	500	1350	2230	3670	1160			276
	M4	1.4	3.8	7.0	8.1	1.4	3.7	6.5	4.4	2.7			2.5
	M5	2.0	4.5	7.7	11.9	2.0	4.5	7.6	10.6	2.5			5.0
	M6	2.3	5.7	9.3	14.5	2.2	5.3	8.5	13.4	3.8			8.6
	M8	2.3	6.1	10.6	17.0	2.2	6.0	9.9	16.3	5.0			21.0
	M10	2.3	6.1	10.6	17.0	2.2	6.0	9.9	16.3	5.1			42.0
R-N SERIES	1/4-20	350	860	1770		400	850	2100		2000	100	60	75
	5/16-18	580	1210	2010		540	1110	2244		2690	180	110	156
	3/8-16	630	1230	2050		590	1180	2110		3700	320	120	276
	1/2-13	620	1320	2240		780	1390	2643		3880	450	220	660
	M6	1.5	3.7	7.8		1.7	3.7	9.3		8.8	16.8	10.6	8.6
	M8	2.5	5.3	8.9		2.6	2.9	9.9		11.9	30.3	12.7	21.0
	M10	2.7	5.4	9.0		2.6	5.2	9.3		16.4	40.2	13.5	42.0
M12	2.7	5.8	9.9		3.4	6.1	11.7		17.2	53.3	48.8	72.0	

**NOTE 1:** Ultimate torque testing should be done using actual customer components and mating hardware due to plating/lubrication variables. AVK's fasteners have been designed to exceed the ultimate torque strength of the appropriate grade/class of mating hardware.

**NOTE 2:** For test data on other AVK products, contact AVK.

**NOTE 3:** R-N Series® Spin-out. Test drop values are keyed steel rivet nuts tested in steel plates and keyed aluminum rivet nut tested in 2024-T4 aluminum plates.



# DECIMAL EQUIVALENTS & DRILL SIZE CHART

DRILL SIZE	INCH (Dec.)	METRIC (mm)	DRILL SIZE	INCH (Dec.)	METRIC (mm)	DRILL SIZE	INCH (Dec.)	METRIC (mm)	DRILL SIZE	INCH (Dec.)	METRIC (mm)	DRILL SIZE	INCH (Dec.)	METRIC (mm)
80	.0135	.343	50	.0700	1,778	22	.1570	3,988	G	.2610	6,630	31/64	.4844	12,304
79	.0145	.368	49	.0730	1,854	21	.1590	4,039	17/64	.2656	6,746	1/2	.5000	12,700
1/64	.0156	.396	48	.0760	1,930	20	.1610	4,089	H	.2660	6,756	33/64	.5156	13,096
78	.0160	.406	5/64	.0781	1,984	19	.1660	4,216	I	.2720	6,909	17/32	.5312	13,492
77	.0180	.457	47	.0785	1,994	18	.1695	4,305	J	.2770	7,036	35/64	.5469	13,891
76	.0200	.508	46	.0810	2,057	11/64	.1719	4,366	K	.2810	7,137	9/16	.5625	14,288
75	.0210	.533	45	.0820	2,083	17	.1730	4,394	9/32	.2812	7,142	37/64	.5781	14,684
74	.0225	.572	44	.0860	2,184	16	.1770	4,496	L	.2900	7,366	19/32	.5938	15,083
73	.0240	.609	43	.0890	2,261	15	.1800	4,572	M	.2950	7,493	39/64	.6094	15,479
72	.0250	.635	42	.0935	2,375	14	.1820	4,623	19/64	.2969	7,541	5/8	.6250	15,875
71	.0260	.660	3/32	.0938	2,383	13	.1850	4,700	N	.3020	7,671	41/64	.6406	16,271
70	.0280	.711	41	.0960	2,438	3/16	.1875	4,763	5/16	.3125	7,938	21/32	.6562	16,667
69	.0292	.742	40	.0980	2,489	12	.1890	4,801	O	.3160	8,026	43/64	.6719	17,066
68	.0310	.787	39	.0995	2,527	11	.1910	4,851	P	.3230	8,204	11/16	.6875	17,463
1/32	.0312	.792	38	.1015	2,578	10	.1935	4,915	21/64	.3281	8,334	45/64	.7031	17,859
67	.0320	.813	37	.104	2,642	9	.1960	4,978	Q	.3320	8,433	23/32	.7188	18,258
66	.0330	.838	36	.1065	2,705	8	.1990	5,055	R	.3390	8,611	47/64	.7344	18,654
65	.0350	.889	7/64	.1094	2,779	7	.2010	5,105	11/32	.3438	8,733	3/4	.7500	19,050
64	.0360	.914	35	.1100	2,794	13/64	.2031	5,159	S	.3480	8,839	49/64	.7656	19,446
63	.0370	.940	34	.1110	2,819	6	.2040	5,182	T	.3580	9,093	25/32	.7812	19,842
62	.0380	.965	33	.1130	2,870	5	.2055	5,220	23/64	.3594	9,129	51/64	.7969	20,241
61	.0390	.991	32	.1160	2,946	4	.2090	5,309	U	.3680	9,347	13/16	.8125	20,638
60	.0400	1,016	31	.1200	3,048	3	.2130	5,410	3/8	.3750	9,525	53/64	.8281	21,034
59	.0410	1,041	1/8	.1250	3,175	7/32	.2188	5,558	V	.3770	9,576	27/32	.8438	21,433
58	.0420	1,067	30	.1285	3,264	2	.2210	5,613	W	.3860	9,804	55/64	.8594	21,829
57	.0430	1,092	29	.1360	3,454	1	.2280	5,791	25/64	.3906	9,921	7/8	.8750	22,225
56	.0465	1,181	28	.1405	3,569	A	.2340	5,944	X	.3970	10,084	57/64	.8906	22,621
3/64	.0469	1,191	9/63	.1406	3,571	15/64	.2344	5,954	Y	.4040	10,262	29/32	.9062	23,017
55	.0520	1,321	27	.1440	3,658	B	.2380	6,045	13/32	.4062	10,317	59/64	.9219	23,416
54	.0550	1,397	26	.1470	3,734	C	.2420	6,147	Z	.4130	10,490	15/16	.9375	23,813
53	.0595	1,511	25	.1495	3,797	D	.2460	6,248	27/64	.4219	10,716	61/64	.9531	24,209
1/16	.0625	1,588	24	.1520	3,861	1/4	.2500	6,350	7/16	.4375	11,113	31/32	.9688	24,608
52	.0635	1,613	23	.1540	3,912	E	.2500	6,350	29/64	.4531	11,509	63/64	.9844	25,004
51	.0670	1,702	5/32	.1562	3,967	F	.2570	6,528	15/32	.4688	11,908	1	1.000	25,400

## DECIMAL EQUIVALENT OF STANDARD GAUGE SHEET ALUMINUM & SHEET METAL

NO. OF GAUGE	GAUGE		NO. OF GAUGE	GAUGE		NO. OF GAUGE	GAUGE	
	ALUM (B & S)	STEEL (U.S. Std.)		ALUM (B & S)	STEEL (U.S. Std.)		ALUM (B & S)	STEEL (U.S. Std.)
10	.1019	.1345	17	.0453	.0538	24	.0201	.0239
11	.0907	.1196	18	.0403	.0478	25	.0179	.0209
12	.0808	.1046	19	.0359	.0418	26	.0159	.0179
13	.0720	.0897	20	.0320	.0359	27	.0142	.0164
14	.0641	.0747	21	.0285	.0329	28	.0126	.0149
15	.0571	.0673	22	.0253	.0299	29	.0113	.0135
16	.0508	.0598	23	.0226	.0269	30	.0100	.0120

## SUGGESTED ASSEMBLY TORQUE VALUES TO PRODUCE CORRESPONDING BOLT LOADS

THREAD SIZE	SAE GRADE 5 BOLTS		
	CLAMP LOAD (lbs.)	ASSEMBLY TORQUE (in.-lbs.)	
		DRY	PLATED
#4-40	380	8	6
#6-32	580	16	12
#8-32	900	30	22
#10-24	1120	43	32
#10-32	1285	49	36
1/4-20	2000	96	75
1/4-28	2300	120	86
5/16-18	3350	204	156
5/16-24	3700	228	168
3/8-16	4950	360	276
3/8-24	5600	420	300

# METRIC CONVERSIONS

<b>LINEAR</b>	Multiply INCHES	by 25.4	to get MILLIMETERS (mm)	Multiply MILLIMETERS (mm)	by .03937	to get INCHES
	Multiply FEET	by 0.3048	to get METERS (m)	Multiply METERS (m)	by 3.281	to get FEET
	Multiply INCHES	by 2.54	to get CENTIMETERS (cm)	Multiply CENTIMETERS (cm)	by .3937	to get INCHES
<b>TORQUE</b>	Multiply INCH-POUNDS	by 0.11298	to get NEWTON-METERS (Nm)	Multiply NEWTON-METERS (Nm)	by 8.851	to get INCH-POUNDS
	Multiply FOOT-POUNDS	by 1.3558	to get NEWTON-METERS (Nm)	Multiply NEWTON-METERS (Nm)	by 0.7376	to get FOOT-POUNDS
<b>FORCE</b>	Multiply POUNDS	by .00445	to get KILONEWTONS (kN)	Multiply KILONEWTONS (kN)	by 224.72	to get POUNDS
<b>PRESSURE</b>	Multiply PSI	by .069	to get BARS	Multiply BARS	by 14.5	to get PSI

## TROUBLE SHOOTING BEFORE PROCEEDING CHECK TO BE SURE THAT THE AVK PRODUCT BEING USED HAS THE PROPER GRIP RANGE FOR THE MATERIAL IT'S BEING INSTALLED INTO.

SYMPTOM	CHECK LIST
1. Tool does not operate	Air lines clear? Tool inlet clear? Tool exhaust clear? Motor Lubrication?
2. Tool runs but stalls before product is installed	Proper tool RPM for thread size being used? Adequate air pressure with tool running? TAK bearing in place and lubricated? Damaged mandrel? Wrong grip part?
3. Tool strips product threads	Proper tool RPM for thread size being used? Too much air pressure? Has the mandrel worn too small?
4. Mandrels wear/break	Is there too much air pressure? Is the tool being held perpendicular during installation?



A-L Series, A-K Series, A-H Series, A-S Series, A-T Series, A-P Series, A-O Series, A-R Series, PreSet, SPP Tool, "Improving The Way We Assemble The World," and Spinwall Technology are trademarks of Avibank Mfg., Inc. A-W Series, R-N Series, Hi Torquer, AVK and  are registered trademarks of Avibank Mfg., Inc.

## AVK INDUSTRIAL PRODUCTS

AVK Industrial Products, a Precision Castparts Company, produces all of its blind threaded captive fasteners at its 80,000 square foot factory in Valencia, California which is located just 35 miles northwest of downtown Los Angeles. We have been manufacturing high quality blind threaded captive fasteners for over 25 years.

**AVK FASTENERS ARE MADE IN THE U.S.A.**

AVK's Quality Management System is registered to ISO/TS16949:2002 and ISO9001:2000

AVK's Environmental Management System is registered to ISO14001:1996

AVK sells its products through Authorized Distributors which are supported by AVK's factory-trained field sales staff. For additional information contact your local AVK distributor or contact AVK.



**DISTRIBUTED BY**

AVK CAGE CODE 78276



# AVK INDUSTRIAL PRODUCTS

**PCC** Company

25323 RYE CANYON ROAD, VALENCIA, CALIFORNIA 91355-1271  
 TELEPHONE: (661) 257-2329 FAX: (661) 257-8043 WEBSITE: [www.avkfasteners.com](http://www.avkfasteners.com)